

---

**User's  
Manual**

**Model DX100/DX200/MV100/MV200  
Fieldbus Communication Interface**

---

---

## Foreword

Thank you for purchasing the YOKOGAWA DAQSTATION or MobileCorder. This User's Manual contains information about the communication function based on the FOUNDATION Fieldbus. To ensure correct use, please read this manual thoroughly before operation.

Keep this manual in a safe place for quick reference in the event a question arises. The following manuals are provided as manuals for the DX100, DX200, MV100, and MV200.

Manual Name	Manual No.	Description
DX100 User's Manual	IM 04L01A01-01E	Explains all functions and procedures of the DX100 excluding the communication functions and the fieldbus functions.
DX200 User's Manual	IM 04L02A01-01E	Explains all functions and procedures of the DX200 excluding the communication functions and the fieldbus functions.
MV100 User's Manual	IM MV100-01E	Explains all functions and procedures of the MV100 excluding the communication functions and the fieldbus functions.
MV200 User's Manual	IM MV200-01E	Explains all functions and procedures of the MV200 excluding the communication functions and the fieldbus functions.

## Notes

- This manual describes the fieldbus functions of the DX100, DX200, MV100, and MV200 style number "S4."
- The contents of this manual are subject to change without prior notice as a result of continuing improvements to the DX's and the MV's performance and functions.
- Every effort has been made in the preparation of this manual to ensure the accuracy of its contents. However, should you have any questions or find any errors, please contact your nearest YOKOGAWA dealer as listed on the back cover of this manual.
- Copying or reproducing all or any part of the contents of this manual without YOKOGAWA's permission is strictly prohibited.
- For details related to the FOUNDATION Fieldbus, refer to the specifications issued by the Fieldbus Foundation.

## Trademarks

- "FOUNDATION" of FOUNDATION Fieldbus is a trademark of Fieldbus Foundation.
- Adobe and Acrobat are trademarks of Adobe Systems incorporated.
- Company and product names that are used in this manual are trademarks or registered trademarks of their respective holders.

## Revisions

First edition: March 2001

---

# How to Use this Manual

## Structure of the Manual

This user's manual consists of the following sections:

Chapter	Title and Contents
1	<b>Overview of Functions</b> Describes the overview of the fieldbus functions.
2	<b>Connecting to the fieldbus</b> Describes the specifications and the installation and wiring procedures.
3	<b>Setting the Functions</b> Describes the functions and the related parameters.
4	<b>Operation</b> Describes how to start the running operation, how to respond to the alert, how to use the simulation function, and how to use the Fieldbus Data screen on the DX and MV.
5	<b>Troubleshooting</b> Describes the status of the input/output data, the block error, and the device status, and the corrective actions to them.
<b>Appendix</b>	Explains the terminology. Describes the data types, the attributes, and the initial values of the parameters.
<b>Index</b>	Provides an index.

## Conventions Used in this Manual

0x..... Denotes a hexadecimal number. Example: 0xf1 (Hexadecimal number “f1”)

V( )..... Denotes a value of the parameter enclosed in parentheses.  
Example: V(ST) (Value of “ST” (Slot Time))

K..... Denotes “1024.” Example: 768 KB (File capacity)

k..... Denotes “1000.”

### Symbols

The following symbols are used in this manual.



Affixed to the instrument. Indicates danger to personnel or instrument and the operator must refer to the User's Manual. The symbol is used in the User's Manual to indicate the reference.

### **WARNING**

Describes precautions that should be observed to prevent injury or death to the user.

### **CAUTION**

Describes precautions that should be observed to prevent minor or moderate injury, or damage to the instrument.

### **Note**

Provides important information for the proper operation of the instrument.

# Contents

Foreword .....	i
How to Use this Manual .....	ii
<b>Chapter 1 Overview of Functions</b>	
1.1 Overview of the DX/MV .....	1-1
1.2 Basic Function .....	1-2
1.3 Link Master Function .....	1-12
<b>Chapter 2 Connecting to the Fieldbus</b>	
2.1 Fieldbus Communication Interface Specifications .....	2-1
2.2 Connecting to the Terminal .....	2-2
<b>Chapter 3 Setting the Fieldbus Functions</b>	
3.1 Overview of the Procedure in Setting the Parameters .....	3-1
3.2 Setting the Node Address, PD Tag, and Block Tag .....	3-4
3.3 Setting Example .....	3-5
3.4 Changing the Block Mode .....	3-8
3.5 Setting the Function That Outputs the Measured Data (AI Function Block) .....	3-10
3.6 Setting the Function That Outputs the Measured Data (MAI Function Block) .....	3-15
3.7 Setting the Function That Receives Measured Data (MAO Function Block) .....	3-16
3.8 Setting the Trend Function (Trend Object) .....	3-20
3.9 Setting the Function That Transmits Alerts .....	3-21
3.10 Prohibiting Writing to Parameters .....	3-25
3.11 Setting the Communications between Function Blocks (Link Object and Virtual Communication Relationship) .....	3-26
3.12 Setting the Schedule of Function Blocks .....	3-29
3.13 Specifying Link Master Device or Basic Device .....	3-30
3.14 Setting the Node Address Range to Be Used (Link Master Function) .....	3-31
3.15 Setting the Operating Conditions of Communications (Link Master Function) .....	3-32
<b>Chapter 4 Operation</b>	
4.1 Starting the Operation and Operations on the Host and the DX/MV .....	4-1
4.2 Handling Alerts .....	4-2
4.3 Using the Simulation Function (AI Function Block) .....	4-5
4.4 Checking the Status of the Communication Input Data .....	4-7
<b>Chapter 5 Troubleshooting</b>	
5.1 Handling the I/O Status .....	5-1
5.2 Handling Block Errors .....	5-8
5.3 Handling the Device Status (DEVICE_STATUS) .....	5-12
5.4 Troubleshooting the Link Master Function .....	5-14
<b>Appendix</b>	
Appendix 1 Terminology .....	App-1
Appendix 2 Parameters .....	App-5

## Index

## 1.1 Overview of the DX/MV

### Fieldbus Standard

The DX/MV can connect to FOUNDATION Fieldbus H1 (transmission speed of 31.25 kb/s) as defined by Fieldbus Foundation.

### Device Type

#### Link Master Device and Basic Device

The DX/MV is a link master device. It has the function as a scheduler. The DX/MV can also operate as a Basic Device without using this the link master function.

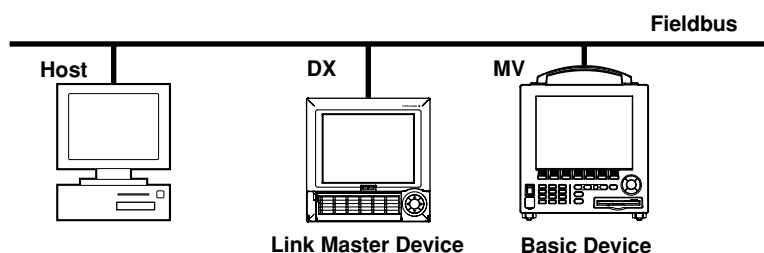

#### Bus Powered Device

The fieldbus function of the DX/MV is driven by the bus power (the DX/MV itself requires its own power supply. The hardware section that controls the fieldbus functions of the DX/MV is driven by the bus power).

### Node Address and PD Tag (Physical Device Tag)

All devices on the fieldbus (except power supplies and terminators) are required to have a unique node address and PD tag. The address is used to specify the device during communications. The PD tag acts as a tag for field devices. The initial values for the node address and PD tag are as follows.

- **Node address: 245**
- **PD tag: DAQSTATION**

### IDs

The DX/MV has the following ID numbers. These values can be confirmed with the parameter values in the resource block\*.

\* For details on the resource block, see section 1.2.

#### IDs

ID	Parameter <sup>*1</sup>	Value (Hexadecimal)	Description
Manufacturer ID	MANUFAC_ID	594543	A fixed ID for YOKOGAWA.
Device type	DEV_TYPE	1801	A fixed ID indicating the DX/MV.
Device revision Revision number	DEV_REV	xx	Device revision number. The value changes when a function is modified.
Device description <sup>*2</sup> Revision number	DD_REV	xx	Device description revision number. The value changes when the device description is modified.

\*1 Parameters in the resource block.

\*2 For details on the device description, see section 3.1.

# 1.2 Basic Function

## Structure of Functions

The DX/MV functions are shown in the figure.

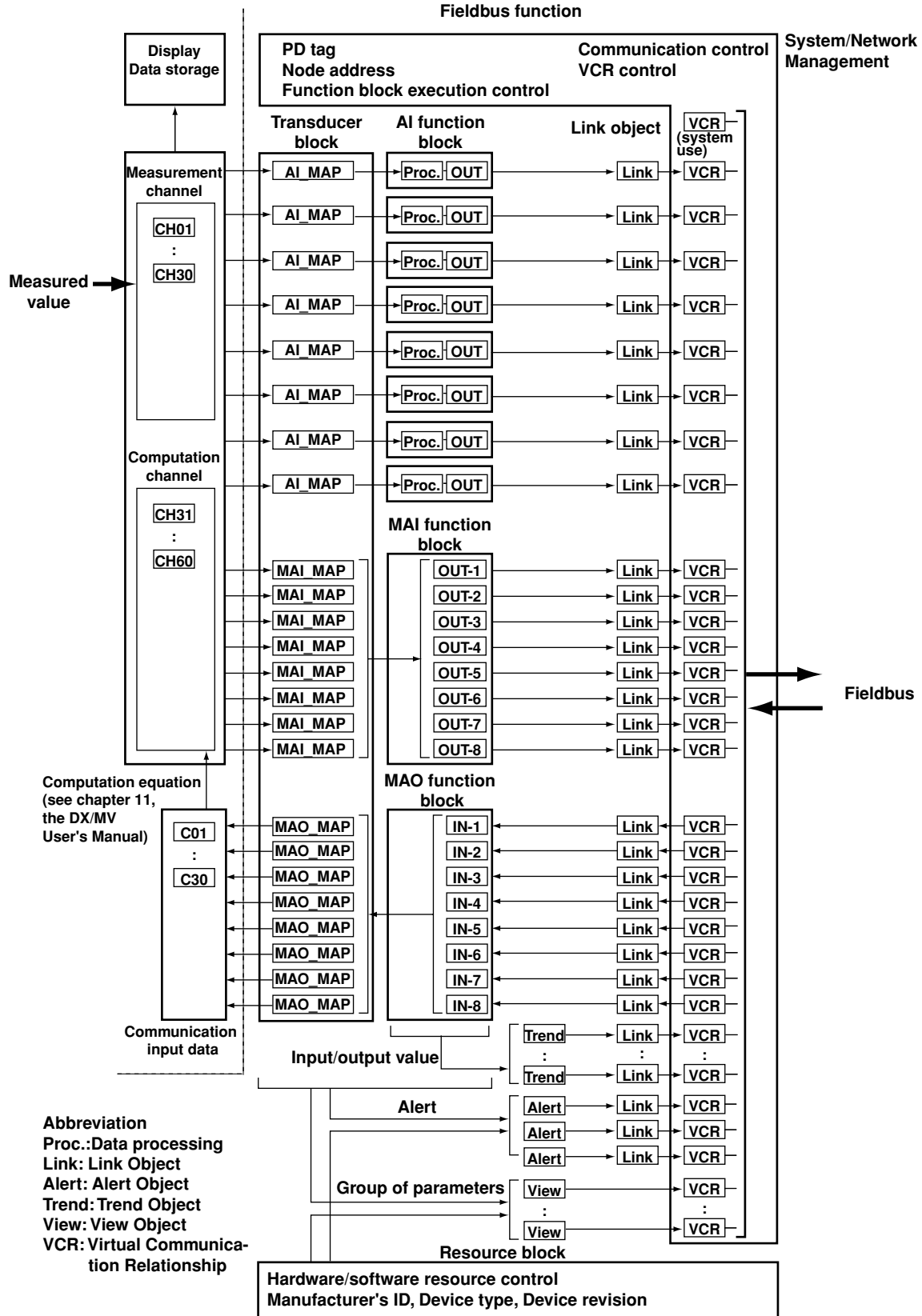

**Resource Block (RB)**

Resource block stores the information of hardware and software resources of the DX/MV. It stores the device information such as Manufacturer's ID, Device Type. Only one resource block exists on each device.

For the resource block parameters, see sections 3.7, 3.9, and appendix 2.

**Transducer Block (TB)**

Transducer block connects the measured, computed, and communication input data on the DX/MV to the function block. It processes measured or computed data so that the AI or MAI can handle, and the data from the MAO so that the computation channel of the DX/MV can handle.

For the parameters of the transducer block, see sections 3.5, 3.6, 3.7, and appendix 2.

**AI (Analog Input) Function Block**

Retrieves the measured and computed data (CH01 to CH60, the number of channels differs depending on models) of the DX/MV to the block and outputs the data to the fieldbus ("OUT" in the figure). At this point, the following processing can be carried out on the measured and computed data ("Proc." in the figure).

- Scaling (scale to value in an appropriate engineering unit)
- Set alarms
- Square root computation
- Filtering
- Low cut filtering (output 0 for values less than or equal to the specified value)

In addition, there is a simulation function that outputs specified values to the fieldbus as measured and computed values (see section 4.3).

The DX/MV has 8 AI function blocks. The transducer block parameter ("AI\_MAP" in the figure) is used to specify the measurement or computation channel data that is to be retrieved to the AI function block. An AI function block can handle a measured or computed datum.

For the AI function block parameters, see section 3.5 and appendix 2.

**MAI (Multiple Analog Input) Function Block**

Retrieves the measured and computed data (CH01 to CH60, the number of channels differs depending on models) of the DX/MV to the block and outputs the data to the fieldbus ("OUT-1" to "OUT-8" in the figure). Up to 8 data sets can be handled simultaneously. The MAI does not have the computation functions as with the AI, but it allows transmission of large amounts of data using a small number of setup parameters with a short execution time.

The DX/MV has one MAI function block. The transducer block parameter ("MAI\_MAP" in the figure) is used to specify the measurement or computation channel data of the DX/MV that is to be retrieved to the MAI function block.

For the MAI function block parameters, see section 3.5 and appendix 2.

**MAO (Multiple Analog Output) Function Block**

Retrieves the data from the fieldbus ("IN-1" to "IN-8" in the figure) so that the DX/MV can use the data as communication input data (CH01 to CH30, the number of communication input data differs depending on models). Up to 8 data sets can be handled simultaneously.

The DX/MV has one MAO function block. The transducer block parameter is used to assign the data sets of MAO function block to the communication input data of the DX/MV. Computation channels are used to display communication input data on DX/MV.

For the MAO function block parameters, see section 3.5 and appendix 2.

### System/Network Management Function

The DX/MV has the following system/network management functions.

#### System/Network Management Function

Function	Description
Address management	Sets the node address and PD tag of the DX/MV.
Time synchronization	Synchronizes the time using the time broadcast from the scheduler.
Tag search	Searches for a specified tag.
Schedule management	Executes the function block according to the schedule.
Communication control	Controls communications initiated by the DX/MV.

For the parameters of the system/network management functions, see sections 3.11 to 3.15, and appendix 2.

#### Virtual Communication Relationship (VCR)

The virtual communication relationship determines the communication method between devices. Once it is configured, communication with other devices can be carried out simply by specifying the virtual communication relationship number. The DX/MV has 31 virtual communication relationships. One of them is for system use and cannot be altered.

For the virtual communication relationship parameters, see section 3.11.

### Link Object

Link object is a function used by the function block to perform communication. There are 26 link objects provided on the DX/MV assuming the following application. The link objects are used by specifying the parameter for each application.

#### Assumed Use of Link Objects

Application	Number of the link object (assumed)
For trends	1
For alerts	1
For the output (OUT) of the AI function block 1 to 8	8
For MAI function block OUT_1 to OUT_8	8
For MAO function block IN_1 to IN_8	8

For the link object parameters, see section 3.11.



## Alert Object

Transmits<sup>\*1</sup> an alert when a specified process alarm occurs or is released in the AI function block, when a block alarm (block error) occurs or is released, when the prohibition of writing to static parameters<sup>\*2</sup> is set or released, or when an update event (when a static parameter<sup>\*2</sup> is overwritten) occurs. The alert shown in the table below can be transmitted for each block.

\*1 Communication starts when a link object and a virtual communication relationship are specified.

\*2 For the attributes of parameters, see appendix 2.

### Cause of an Alert

Block	Process Alarm	Block Alarm, Write Lock Alarm	Update Event
RB		Block alarm, Write prohibition alarm	Update event
TB		Block alarm	Update event
AI-1, AI-2, AI-3, AI-4, AI-5, AI-6, AI-7, AI-8	HI_HI alarm x 8 HI alarm x 8 LO alarm x 8 LO_LO alarm x 8	Block alarm x 8	Update event x 8
MAI		Block alarm	Update event
MAO		Block alarm	Update event
Number of causes (total)	32	13	12

The DX/MV has three alert objects. When multiple alarms occur, alert is transmitted by using these alert objects. However, if there is no free alert object, the transmission is put on wait.

For the alert object parameters, see appendix 2. For the parameters related to alert transmission, see section 3.9.

## Trend Object

The trend object samples and holds the values of a specified input/output parameter, and periodically transmits\* the values in groups (16 samples).

\* Communication starts when a trend object, link object, and a virtual communication relationship are specified.

There are eight trend objects in the DX/MV. The trend of the parameters in the table below can be transmitted.

### Trend Target Parameters

Function Block	Target parameter
Eight AIs	FIELD_VAL, PV, OUT
MAI	OUT_1, OUT_2, OUT_3, OUT_4, OUT_5, OUT_6, OUT_7, OUT_8
MAO	IN_1, IN_2, IN_3, IN_4, IN_5, IN_6, IN_7, IN_8
Total	40

The execution time (see p.1-11) that is specified for the FB of the DX/MV is a value that is derived with the premise that up to one trend object is to be used. If multiple trend objects are used on a single function block, the execution time may exceed the specified value (30 ms) and cause problems in which the function block is not executed according to the schedule.

For the trend object parameters, see appendix 2. For the parameter settings, see section 3.8.

## View Object

View object is used when reading several parameters of a function block at once. By collectively retrieving the parameters,\* the load of the communication process is reduced. There are four types of view objects.

\* The grouping of the parameters in VIEW\_1 to VIEW\_4 is fixed for each block and cannot be changed.

### View Object Types

No.	Symbol	Description
1	VIEW_1	A set of dynamic parameters* required by the operator for operation (OUT, PV, IN, MODE, etc).
2	VIEW_2	A set of static parameters* that need to be indicated to the operator (scaling parameter, etc).
3	VIEW_3	A set of all dynamic parameters.*
4	VIEW_4	A set of static parameters* not included in VIEW_2.

\* For the parameter attributes, see appendix 2.

All the blocks of the DX/MV have one of each type VIEW\_1 to VIEW\_4. Each view object can read them using the following index numbers.\*

\* For the index numbers, see "Parameters" in this section.

### Index Number of the View Object

Function Block	VIEW_1	VIEW_2	VIEW_3	VIEW_4
RB	40100	40101	40102	40103
TB	40200	40201	40202	40203
AI-1	40400	40401	40402	40403
AI-2	40410	40411	40412	40413
AI-3	40420	40421	40422	40423
AI-4	40430	40431	40432	40433
AI-5	40440	40441	40442	40443
AI-6	40450	40451	40452	40453
AI-7	40460	40461	40462	40463
AI-8	40470	40471	40472	40473
MAI	40900	40901	40902	40903
MAO	41000	41001	41002	41003

The parameters of VIEW\_1 through VIEW\_4 that are specified for each function block are stored in order in the view object.

For example, the view object corresponding to VIEW\_2 of the transducer block (index number 40201) has the following construction.

### Construction of the View Object Corresponding to VIEW\_2 of the TB

Index No.	Parameter
40201	ST_REV TRANSDUCER_TYPE

The parameters that are stored in VIEW\_1 through VIEW\_4 of each block are shown below. The value in the VIEW column represents the parameter size (in bytes). "R" denotes the relative index No. (see p.1-10).

**Parameters in the View Object of the Resource Block**

R	Parameter	VIEW_1	VIEW_2	VIEW_3	VIEW_4
1	ST_REV	2	2	2	2
2	TAG_DESC				
3	STRATEGY				2
4	ALERT_KEY				1
5	MODE_BLK	4		4	
6	BLOCK_ERR	2		2	
7	RS_STATE	1		1	
8	TEST_RW				
9	DD_RESOURCE				
10	MANUFAC_ID				4
11	DEV_TYPE				2
12	DEV_REV				1
13	DD_REV				1
14	GRANT_DENY		2		
15	HARD_TYPES				2
16	RESTART				
17	FEATURES				2
18	FEATURE_SEL		2		
19	CYCLE_TYPE				2
20	CYCLE_SEL		2		
21	MIN_CYCLE_T				4
22	MEMORY_SIZE				2
23	NV_CYCLE_T		4		
24	FREE_SPACE		4		
25	FREE_TIME	4		4	
26	SHED_RCAS		4		
27	SHED_ROUT		4		
28	FAULT_STATE	1		1	
29	SET_FSTATE				
30	CLR_FSTATE				
31	MAX_NOTIFY				1
32	LIM_NOTIFY		1		
33	CONFIRM_TIME		4		
34	WRITE_LOCK		1		
35	UPDATE_EVT				
36	BLOCK_ALM				
37	ALARM_SUM	8		8	
38	ACK_OPTION				2
39	WRITE_PRI				1
40	WRITE_ALM				
41	ITK_VER				2
42	SOFT_REV				
43	SOFT_DESC				
44	SIM_ENABLE_MSG				
45	DEVICE_STATUS_1			4	
46	DEVICE_STATUS_2			4	
47	DEVICE_STATUS_3			4	
48	DEVICE_STATUS_4			4	
49	DEVICE_STATUS_5			4	
50	DEVICE_STATUS_6			4	
51	DEVICE_STATUS_7			4	
52	DEVICE_STATUS_8			4	
	Total	22	30	54	31

**Parameters in the View Object of the Transducer Block**

R	Parameter	VIEW_1	VIEW_2	VIEW_3	VIEW_4
1	ST_REV	2	2	2	2
2	TAG_DESC				
3	STRATEGY				2
4	ALERT_KEY				1
5	MODE_BLK	4		4	
6	BLOCK_ERR	2		2	
7	UPDATE_EVT				
8	BLOCK_ALM				
9	TRANSDUCER_DIRECTORY				
10	TRANSDUCER_TYPE	2	2	2	2
11	XD_ERROR	1		1	
12	COLLECTION_DIRECTORY				
13	AI_MAP				16
14	MAI_MAP				16
15	MAO_MAP				16
16	ALARM_SUM	8		8	
17	DEV_ID				
18	DEV_KEY				
19	EEPROM_STATE				
20	UART_STATISTICS				
21	STACK_STATISTICS_1				
22	STACK_STATISTICS_2				
23	STACK_CONF				
24	EXEC_FB_CNT				
	Total	19	4	19	55

**Parameters in the View Object of the AI Function Block**

R	Parameter	VIEW_1	VIEW_2	VIEW_3	VIEW_4
1	ST_REV	2	2	2	2
2	TAG_DESC				
3	STRATEGY				2
4	ALERT_KEY				1
5	MODE_BLK	4		4	
6	BLOCK_ERR	2		2	
7	PV	5		5	
8	OUT	5		5	
9	SIMULATE				
10	XD_SCALE		11		
11	OUT_SCALE		11		
12	GRANT_DENY		2		
13	IO_OPTS				2
14	STATUS_OPTS				2
15	CHANNEL				2
16	L_TYPE				1
17	LOW_CUT				4
18	PV_FTIME				4
19	FIELD_VAL	5		5	
20	UPDATE_EVT				
21	BLOCK_ALM				
22	ALARM_SUM	8		8	
23	ACK_OPTION				2
24	ALARM_HYS				4

## 1.2 Basic Function

R	Parameter	VIEW_1	VIEW_2	VIEW_3	VIEW_4
25	HI_HI_PRI				1
26	HI_HI_LIM				4
27	HI_PRI				1
28	HI_LIM				4
29	LOW_PRI				1
30	LOW_LIM				4
31	LOW_LOW_PRI				1
32	LOW_LOW_LIM				4
33	HI_HI_ALM				
34	HI_ALM				
35	LOW_ALM				
36	LOW_LOW_ALM				
	Total	31	26	31	46

R	Parameter	VIEW_1	VIEW_2	VIEW_3	VIEW_4
16	MO_OPTS				2
17	FSTATE_TIME				4
18	FSTATE_VAL1				4
19	FSTATE_VAL2				4
20	FSTATE_VAL3				4
21	FSTATE_VAL4				4
22	FSTATE_VAL5				4
23	FSTATE_VAL6				4
24	FSTATE_VAL7				4
25	FSTATE_VAL8				4
26	FSTATE_STATUS	1		1	
27	UPDATE_EVT				
28	BLOCK_ALM				
	Total	49	2	49	45

### Parameters in the View Object of the MAI Function Block

R	Parameter	VIEW_1	VIEW_2	VIEW_3	VIEW_4
1	ST_REV	2	2	2	2
2	TAG_DESC				
3	STRATEGY				2
4	ALERT_KEY				1
5	MODE_BLK	4		4	
6	BLOCK_ERR	2		2	
7	CHANNEL				2
8	OUT_1	5		5	
9	OUT_2	5		5	
0	OUT_3	5		5	
11	OUT_4	5		5	
12	OUT_5	5		5	
13	OUT_6	5		5	
14	OUT_7	5		5	
15	OUT_8	5		5	
16	UPDATE_EVT				
17	BLOCK_ALM				
	Total	48	2	48	7

### Parameters in the View Object of the MAO Function Block

R	Parameter	VIEW_1	VIEW_2	VIEW_3	VIEW_4
1	ST_REV	2	2	2	2
2	TAG_DESC				
3	STRATEGY				2
4	ALERT_KEY				1
5	MODE_BLK	4		4	
6	BLOCK_ERR	2		2	
7	CHANNEL				2
8	IN_1	5		5	
9	IN_2	5		5	
10	IN_3	5		5	
11	IN_4	5		5	
12	IN_5	5		5	
13	IN_6	5		5	
14	IN_7	5		5	
15	IN_8	5		5	

## Parameters

The fieldbus function of the DX/MV is configured by setting parameters that belong to the Virtual Field Devices (see appendix 1). Parameters for the system/network management function are in the Management Information Base Virtual Field Device (MIB-VFD), and parameters for function blocks are in the Function Block Virtual Field Device (FB-VFD).

**Management Information Base  
Virtual Field Device (MIB-VFD)**

Index No.	Function
0 :	Common items
258 :	System management
290 :	Network management

**Function Block  
Virtual Field Device (FB-VFD)**

Index No.	Function
0 :	Common items
1000 :	Resource block
2000 :	Transducer block
4000 :	AI function block-1
4100 :	AI function block-2
4200 :	AI function block-3
4300 :	AI function block-4
4400 :	AI function block-5
4500 :	AI function block-6
4600 :	AI function block-7
4700 :	AI function block-8
9000 :	MAI function block
10000 :	MAO function block
30000 :	Link object
31000 :	Alert object
32000 :	Trend Object
40000 :	View object

## 1.2 Basic Function

---

### Index No., Sub Index No., Relative Index No.

The DX/MV assigns the index numbers to the parameters. If the parameter consists of a set of sub parameters, sub parameters have sub index numbers. In addition, the parameters of the resource block, transducer block, AI function blocks, MAI function block, and MAO function block have a relative index number that are assigned the values 0, 1, 2, and so on from the head of the block.

For example, the parameters of the resource block are stored in the area corresponding to index numbers 1000 to 1052. The parameters are assigned relative index numbers from 0 to 52. The parameter "MODE\_BLK" at the relative index number 5 has sub parameters with subindex numbers 1 to 4.

### Parameters of the Resource Block

Index No.	Relative Index No.	Parameter
1000	0	Block
1001	1	ST_REV
1002	2	TAG_DESC
1003	3	STRATEGY
1004	4	ALERT_KEY
1005	5	MODE_BLK
		<b>Sub Index No.    Sub parameter</b>
		1                  Target
		2                  Actual
		3                  Permitted
		4                  Normal
1006	6	BLOCK_ERR
:	:	:
1051	51	DEVICE_STATUS_7
1052	52	DEVICE_STATUS_8

A parameter is identified using the index number, sub index number and the relative index number.

For the parameters of the DX/MV, see appendix 2.

## Execution of the Function Block

### Execution Time

Execution time refers to the time that is required to execute the process of the function block. The table below shows the execution times that are set before shipping. The time cannot be changed.

The execution time is set to a value with a slight margin. However, if there is too much information to be processed, the process may not be completed within the execution time. In such case, lighten the processing load of the block.

### Period of Execution

The period of execution is the time duration at which the process of each block is repeated. Modify the period of execution as necessary. However, since the I/O data is updated at the period of execution of the transducer block (250 ms), specifying a shorter period may result in the same value to be retrieved at consecutive periods.

**Block Execution Time and Period of Execution**

Block	Execution Time	Period of Execution
Resource block	Self-run	Self-run (500 ms)
Transducer block	Self-run	Self-run (250 ms)
AI function block	30 ms	Determined by the schedule.
MAI function block	30 ms	Determined by the schedule.
MAO function block	30 ms	Determined by the schedule.

### Schedule

Since the DX/MV can only process the function blocks sequentially, the function block 2 may not be executed, as it is scheduled to run in parallel with the function block 1. Scheduling is not required for the resource and transducer blocks, since they are self-run.

#### Schedule That Cannot Be Executed

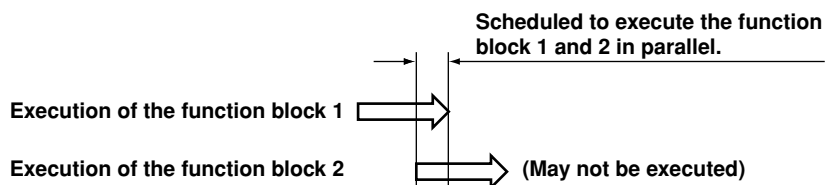

## Communication with Other Field Device

To transmit data to or receive data from other devices on the fieldbus, the link objects and the virtual field devices (VCR) are used.

## 1.3 Link Master Function

### Link Master Functions

The following scheduler functions are supported.

#### Link Master Functions

Function <sup>*1</sup>	Description
Detection of New Devices on the Fieldbus	Periodically checks the devices on the fieldbus for new devices.
Control of Unscheduled Communications	Provides permissions to all devices on the fieldbus in sequence and periodically when unscheduled communication is possible.
Control of Scheduled Communications	Instructs publishing/subscribing of measured data to field devices according to the schedule.
Time Synchronization	Periodically broadcasts time information. This allows all devices to have the same time information.
Live List Equalization	Broadcasts the live list (LL) <sup>*2</sup> to all the link master devices on the fieldbus. This allows all the link master devices to have the same live list.
Assignment of the Scheduler Rights	Assigns the scheduler rights to other link master devices.

\*1 The DX/MV does not support the transmission of RR (Round Trip Delay Reply) and Long Address.

\*2 Live list is a list of devices that are detected on the fieldbus.

#### Transition to Scheduler

If the DX/MV determines that there is no scheduler on the fieldbus such as when starting up a fieldbus or a preexisting scheduler malfunctions, it declares that it will become a scheduler and makes the transition. For the transition condition to the scheduler, see appendix 1, "Terminology."



## 2.1 Fieldbus Communication Interface Specifications

The fieldbus communication interface specifications of the DX/MV are indicated below.

### Fieldbus Communication Interface Specifications

Item	Description	
Terminal type	M4 screws	
Output signal	Digital signal based on the FOUNDATION Fieldbus H1	
Physical layer	113 (standard-power signaling, bus powered, non I.S.)	
Number of connected devices <sup>*1</sup>	Up to 32 (Including the DX/MV)	
Connection	Multidrop	
Intrinsic safety	Not applicable	
Transmission mode	Transmission mode based on the FOUNDATION Fieldbus H1	
Transmission speed	31.25 kbps	
Communication line condition	Power supplied by the communication line Supply voltage: 9 to 32 VDC Supply current: 16.5 mA (maximum)	
Isolation	Dielectric strength (between communication terminals and the ground terminal): 500 Vrms (50/60 Hz, 1 min.)	
Transmission distance <sup>*2</sup>	<b>Cable type</b>	<b>Maximum cable length (reference value)</b>
	Type A (twisted pair, shielded per pair) #18AWG (0.82 mm <sup>2</sup> )	1900 m
	Type A (twisted pair, shielded collectively) #22AWG (0.32 mm <sup>2</sup> )	1200 m

\*1 "32" means the theoretical number of connectable devices. The actual number of connectable devices varies depending on the installation conditions.

\*2 The transmission distance is limited by the cable type, the power supply to the bus, etc.

## 2.2 Connecting to the Terminal

### Terminal Arrangement

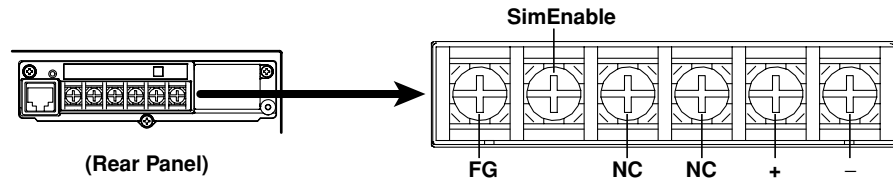

#### Terminals

Terminal	Description
FG (Frame Ground)	Case ground of the DX/MV.
SimEnable	Connect to FG when using the simulation function. For information on how to use this terminal, see section 4.3.
NC (No Connection)	Not used.
+	Connect to the cable on the positive side of the fieldbus power supply. This terminal is isolated from the ground terminal (including FG terminal).
-	Connect to the cable on the negative side of the fieldbus power supply. This terminal is isolated from the ground terminal (including FG terminal).

### Connection Procedure



#### WARNING

To prevent the possibility of electric shock, connect the cables with the power turned OFF.

#### How to Connect the Cable

As shown in the following figure, attach a crimp-on lug with isolation sleeves for 4 mm screws to the end of the cable. Keep the exposed section from the end of the shield within 5 cm.

**SimEnable terminal (For information on how to use this terminal, see section 4.3.)**

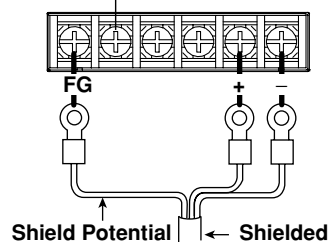

#### Attaching the Clamp Filter

Attach the clamp filter that came with the package to the cable. Attach it near the DX/MV's terminal.

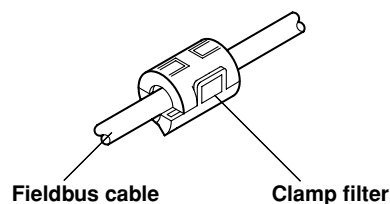

## 3.1 Overview of the Procedure in Setting the Parameters

### Scope of This Chapter

This chapter describes the settings of the main parameters using the expression when the Device Description of the DX/MX (see below) is used. For parameters that are not described in this chapter, see appendix 2.

The procedure in setting the parameters varies depending on the configurator that you are using. See the respective user's manual.

### Integrating the Device Description (DD)

Before connecting the DX/MV to the fieldbus, you will install the Device Description of the DX/MV to the host or the configurator. The DD allows devices that are made by various manufacturers to be operated in a uniform manner on the fieldbus (interoperability).

When you use the DD, the parameters and settings are displayed using easy-to-understand symbols. For example, a configurator may display values using hexadecimal symbols such as "0x08." When the DD is installed, it is displayed using easy-to-understand symbols such as "Auto."

The DD can be thought of as a driver software for the device.

#### Obtaining the DD

The DD file is included in the DAQSTANDARD Software CD-ROM.

- **Pass name:** \Fieldbus\DAQ\_F00\594543\1801

You can also obtain the DD file in the following way.

- **Yokogawa's Home Page**  
Download the DD file from Yokogawa's home page.
- **The Fieldbus Foundation**  
Please contact the Fieldbus Foundation.

#### Installing the DD

For the procedure of installing the DD, see the user's manual for the configurator.

### Adding the DX/MV to the Fieldbus

The following figure shows the steps to add the DX/MV to the fieldbus.

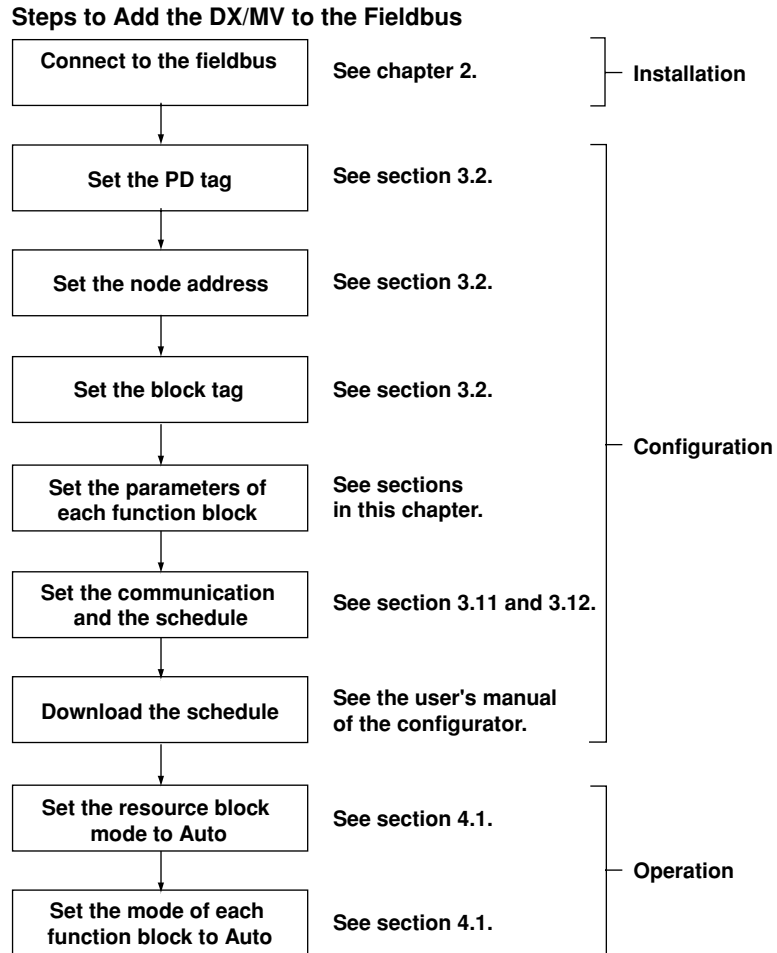

#### Installation

See chapter 2.

#### Setting the PD Tag

The initial PD tag of the DX/MV is "DAQSTATION." The PD tag must be unique on the fieldbus. For the setting procedure, see section 3.2.

#### Setting the Node Address

The initial node address of the DX/MV is 245 (0xf5). The node address must be unique on the fieldbus. For the setting procedure, see section 3.2.

#### Setting the Block Tag

The block tag is the name of the block. Each block of all the devices on the fieldbus (resource block, transducer block, AI function block, MAI function block, and MAO function for the DX/MV) has a block tag. The block tag must be unique on the fieldbus. For the setting procedure, see section 3.2.

#### Setting the Parameters of Each Function Block

This chapter describes the configuration of the main parameters. For the procedure in setting the parameters, see the respective section in this chapter.

- **Configuration Procedure of the Block Parameters**

Carry out the following steps in setting the parameters of each function block (resource block, transducer block, AI, MAI, and MAO function blocks). For the procedure in changing the mode, see section 3.4.

1. Set the block mode of the block to a mode\* that allows the relevant parameter to be written.

\* For details on the modes that allow writing of each parameter, see appendix 2.

2. Set the parameter values.

#### Setting the Communication and the Schedule

You must specify the following items. The communication method is specified using the parameters of the link object and virtual communication relationship.

- Link between function blocks\*<sup>1</sup>
- Alert transmission
- Trend transmission
- Schedule\*<sup>2</sup>

\*<sup>1</sup> For the link object and virtual communication relationship (VCR) to specify links, see section 3.11.

\*<sup>2</sup> Determine the control period and the execution timing of the function blocks and create a schedule. See section 3.12.

#### Downloading the Schedule

Download the schedule that you specified to the DX/MV. For the procedure in downloading the schedule, see the user's manual of the configurator that you are using.

#### Operation

See section 4.1.

## 3.2 Setting the Node Address, PD Tag, and Block Tag

### Note

The PD tag, node address, and block tag must be unique on the fieldbus. When connecting multiple DX/MV to the fieldbus, we recommend you connect and configure one DX/MV at a time.

### Setting the PD Tag

You cannot write the PD tag directly to the parameter (PD\_TAG) of the Management Information Base Virtual Field Device (MIB-VFD). It is set using a special communication service. Set the PD tag according to the operation of the configurator that you are using.

Set the PD tag using up to 32 alphanumeric characters. The specified PD tag can be confirmed through the following parameter.

#### Parameter for Displaying the PD Tag (MIB)

Index	Parameter	Description
271	PD_TAG	Displays the PD tag. The initial value is "DAQSTATION."

### Setting the Node Address

You cannot write the node address directly to the parameter (This Node of DLME\_BASIC\_INFO) of the Management Information Base Virtual Field Device (MIB-VFD). It is set using a special communication service. Set the PD tag according to the operation of the configurator that you are using. The selectable range of node addresses is the node address range that is managed by the scheduler.

The specified node address can be confirmed through the following parameter.

#### Parameter for Displaying the Node Address (MIB)

Index	Parameter	Description
361	DLME_BASIC_INFO	
4	This Node	Displays the node address. The initial value is 245 (0xf5).

### Setting the Block Tag

The block tag is included in the first parameter of each block (BLOCK, relative index number of 0). It is set using a special communication service. Set the PD tag according to the operation of the configurator that you are using.

Set the block tag using up to 32 alphanumeric characters. The initial value of the block tag of the DX/MV is as follows:

#### Initial Value of the Block Tag

Block	Initial Value of the Block Tag
Resource block	RB
Transducer block	TB
AI function block	AI-1, AI-2, AI-3, AI-4, AI-5, AI-6, AI-7, AI-8
MAI function block	MAI-1
MAO function block	MAO-1

### 3.3 Setting Example

Explains the settings of DX/MV using an example below.

#### Measurement Loop and the Schedule

##### Measurement Loop

Retrieves the OUT of an AI function block of a field device and pass it to the communication input data C01.

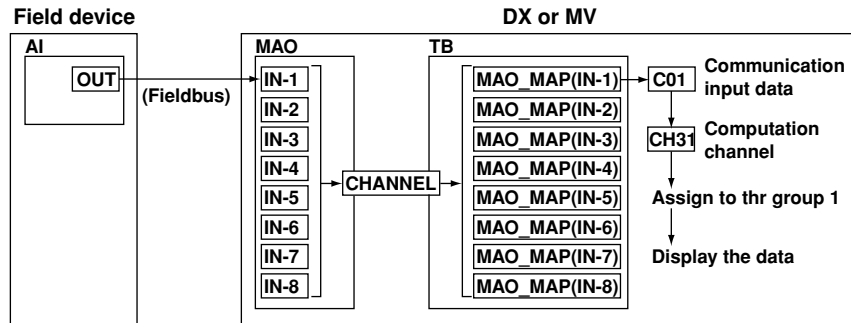

##### Schedule

Executes the MAO function block of the DX/MV as follows.

- Control period: 250 ms
- Offset time for MAO execution of the DX/MV: 70 ms
- Execution time of the MAO function block of the DX/MV: 30 ms

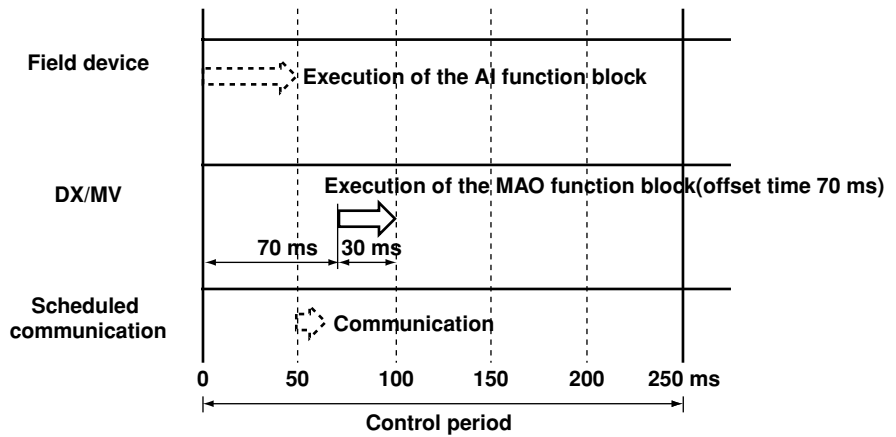

## Settings

### Setting the Block Mode to OOS

1. Set the block mode of the resource block (RB), transducer block (TB), and MAO function block to OOS (see section 3.4).

### Communication

2. Set the communication to subscribe OUT of the AI function block of the field device to IN-1 of the MAO function block. Setting Link Object and related Virtual Communication Relationship is necessary (see section 3.11).

### Connection between MAO Function Block and the Transducer Block

3. CHANNEL used to connect the MAO function block and the transducer block is 10 and not changeable (MAO, relative index number 7, see section 3.7).

### Connection between Transducer Block and the Communication Input Data C01

4. Set "1" to MAO\_MAP(IN-1) on the transducer block to connect the communication input data C01, and set "0" to MAO\_MAP(IN-2) through MAO\_MAP(IN-8) as they are not used (see section 3.7).

#### **MAO\_MAP (TB, relative index number 15)**

MAO\_MAP (IN-1): 1, MAO\_MAP (IN-2) through MAO\_MAP (IN-8): 0

### Schedule

5. Set the schedule by setting parameters on the Management Information Base Virtual Field Device (see section 3.12).

#### **MACRO\_CYCLE\_DURATION (MIB, index number 269)**

Set 8000 (= 250 x 32), as the unit is 1/32 ms.

#### **FB\_START\_ENTRY.10 (MIB, index number 285)**

##### **Start Time Offset**

Set 2240 (= 70 ms x 32), as the unit is 1/32 ms.

##### **Fb Object Index**

Set 10000, the first index number of the MAO function block.

### Download

6. Download the schedule to the DX/MV. For the operating procedure, see the user's manual of the configurator that you are using.

### Settings on the DX/MV

#### • **Computation Channel**

7. Set the computation channel CH31 as follows:  
Equation: C01  
Lower limit of span, Upper limit of span: Set the lower and upper limits of span  
Unit: Set the unit.



- **Channel Assignment to Group**

8. Assign the channel 31 to Group 1.

**Confirmation**

- **Start Computation**

9. Start computation by pressing the FUNC key and then the MATH START soft key.

- **Set the Block Mode to Auto**

10. Set the block mode of the resource block, transducer block, and MAO function block to Auto (see section 3.4).

- **Displaying Data**

11. The computation channel 31 is displayed on the screen for Group 1.  
If “+\*\*\*\*\*” is displayed as a value, the data have some abnormality. Confirm the status of IN-1 and take corrective actions (see section 5.1).  
The status of the communication input data can be confirmed on the FIELDBUS DATA screen of the DX/MV (see section 4.4).

## 3.4 Changing the Block Mode

The MODE\_BLK is a parameter that is used to set the mode of the block.

### Block Mode Parameter (RB, TB, AI, MAI, and MAO)

Relative Index No.	Parameter	Write Mode
5	MODE_BLK	
1	Target	All modes
2	Actual	-
3	Permitted	All modes
4	Normal	All modes

- **Target**

Set the mode you want the block transit to. Only the modes specified in Permitted are acceptable. For information about the mode and set value, see section “Permitted.”

- **Actual**

Indicates the current mode of the block. You cannot set this value.

- **Permitted**

The parameter that indicates the modes that can be set to Target and Normal. The following table shows the modes that each block of the DX/MV can transit to. Set the value within this range.

### Modes That the Block Can Transit to

Block	Mode		
Resource block	Auto		OOS
Transducer block	Auto		OOS
AI function block	Auto	Man	OOS
MAI function block	Auto	Man	OOS
MAO function block	Auto	LO	OOS

### Auto

Condition in which the operations are carried out automatically.

### Man (Manual)

The AI and MAI function blocks stop updating the output value. In this mode, you can manually write values to the block parameters and output them. However, you cannot change the parameter status. The following parameters are applicable.

- **AI-1 to AI-8: OUT**
- **MAI: OUT\_1 to OUT\_8**

### OOS (Out of Service)

Condition in which the operation of the block is stopped.

### LO (Local Override)

The mode of the MAO function block transits to LO, when the value of FAULT\_STATE (relative index No. 28) of the resource block is “Active(value is “2”).”

The value of Permitted, Target, and Normal is a single byte bit sequence. The correspondence between the bits and modes are as follows:

#### Parameter Value

Bit	Symbol
0	-
1	-
2	-
3	Auto
4	Man
5	Local Override (LO)*
6	-
7	Out of Service (OOS)

\* You cannot set LO (Local Override) to the MAO Target.

- **Normal**

This parameter is provided for the configurator. It is used to specify the transition destination when returning to normal operation. Only the modes specified in Permitted are acceptable. For information about the mode and set value, see section "Permitted."

## 3.5 Setting the Function That Outputs the Measured Data (AI Function Block)

### Structure of AI Function Block

The following figure shows the data process flow and the main parameters. For SIMULATE and MODE\_BLK, see sections 4.3 and 3.4 respectively.

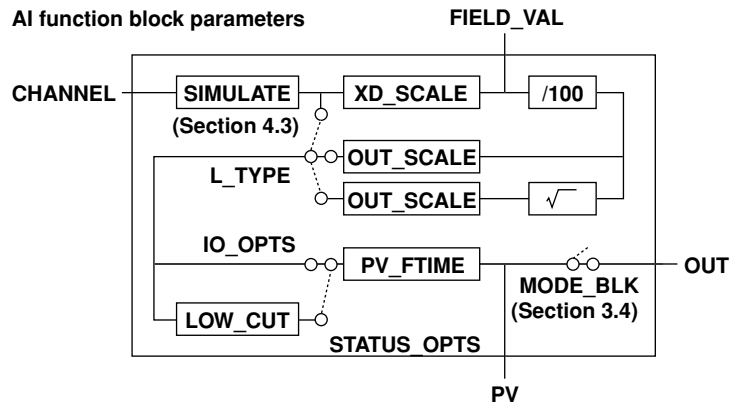

The parameters in the framed area specifies the data process procedures.  
The dotted lines denote options specified by the parameters.

### Measured/Computed Data to Be Connected

The connection between the measured and computed data of the DX/MV and the transducer block is set using AI\_MAP of the transducer block. In addition, the connection between the transducer block and each AI function block is set using CHANNEL of the AI function block.

### Setting the Connection between the Measured/Computed Data and the Transducer Block

#### Parameter for Setting the Connection (TB)

Relative Index No.	Parameter	Write Mode
13	AI_MAP	
	1 CHANNEL-1(AI_MAP)	OOS
	2 CHANNEL-2(AI_MAP)	OOS
	3 CHANNEL-3(AI_MAP)	OOS
	4 CHANNEL-4(AI_MAP)	OOS
	5 CHANNEL-5(AI_MAP)	OOS
	6 CHANNEL-6(AI_MAP)	OOS
	7 CHANNEL-7(AI_MAP)	OOS
	8 CHANNEL-8(AI_MAP)	OOS

- **CHANNEL-1 to CHANNEL-8**

Sets the channel number of the DX/MV (1 through 60) to connect to AI-1 to AI-8.

### Setting the Connection between the Transducer Block and Each AI

#### Parameter for Setting the Connection (AI)

Relative Index No.	Parameter	Write Mode
15	CHANNEL	OOS

- **CHANNEL**

A CHANNEL parameter exists for each AI. Set the CHANNEL number (1 to 8) of AI\_MAP to connect to each AI.

**Process Procedure of the Measured/Computed Data**

L\_TYPE specifies how to process the measured/computed data from the transducer block to create FIELD\_VAL or PV.

**Parameter for Specifying the Process Procedure of the Measured/Computed Data (AI)**

Relative Index No.	Parameter	Write Mode
16	L_TYPE	Man, OOS

• **L\_TYPE**

Specify the process procedure from the table.

**L\_TYPE Value**

Value	Symbol	Description
1	Direct	Make the value from the TB into FIELD_VAL and PV.
2	Indirect	Scale FIELD_VAL to create PV.
3	Ind Sqr Root	Take the square root and scale FIELD_VAL to create PV.

FIELD\_VAL and PV are calculated in the equations below. The [EU at 100%] and [EU at 0%] of FIELD\_VAL are set using the XD\_SCALE parameter; the [EU at 100%] and [EU at 0%] of PV are set using the OUT\_SCALE parameter (see the “Scaling” section).

• **When Set to Direct**

$$\text{FIELD\_VAL} = 100(\text{SIMULATE}^* - [\text{EU at 0\%}] / ([\text{EU at 100\%}] - [\text{EU at 0\%}]))$$

$$\text{PV} = \text{SIMULATE}^*$$

\* Output value of SIMULATE. During normal operation, the value from the transducer block is output from SIMULATE. When using the simulation function, the simulation value is output from SIMULATE (see section 4.3).

• **When Set to Indirect**

FIELD\_VAL: Same as when set to Direct

$$\text{PV} = (\text{FIELD\_VAL} / 100) ([\text{EU at 100\%}] - [\text{EU at 0\%}]) + [\text{EU at 0\%}]$$

• **When Set to Ind Sqr Root**

FIELD\_VAL: Same as when set to Direct

$$\text{PV} = \sqrt{(\text{FIELD\_VAL} / 100)} \times ([\text{EU at 100\%}] - [\text{EU at 0\%}]) + [\text{EU at 0\%}]$$

**Note**

When using the filter, PV delays from SIMULATE or FIELD\_VAL because of the time constant of the filter.

### 3.5 Setting the Function That Outputs the Measured Data (AI Function Block)

---

#### Scaling

XD\_SCALE and OUT\_SCALE are for FIELD\_VAL and PV, respectively.

##### Scaling Parameter (AI)

Relative Index No.	Parameter	Write Mode
10	XD_SCALE	
	1 EU at 100%	OOS
	2 EU at 0%	OOS
	3 Units Index	OOS
	4 Decimal Point	OOS
11	OUT_SCALE	
	1 EU at 100%	OOS
	2 EU at 0%	OOS
	3 Units Index	OOS
	4 Decimal Point	OOS

- **EU at 100%, EU at 0%**

##### For XD\_SCALE

Specify the values with an engineering unit that correspond to 0 to 100% of FIELD\_VAL.

##### For OUT\_SCALE

Specify the values with an engineering unit that correspond to 0 to 100% of PV.

- **Units Index, Decimal Point**

Set the unit and the number of display digits below the decimal point if the device used to display the data needs these information. Units Index is specified through a value that correspond to the unit.

##### Units Index Value (representative examples only)

Value	Unit
1001	°C
1243	mV
1240	V
1342	%

##### Note

The set values for Unit Index and Decimal Point do not apply to FIELD\_VAL, PV and OUT. Use Unit Index and Decimal Point if the device to display FIELD\_VAL, PV or OUT need these information.

---

**Example**

When the measured value from the TB is 1 to 5 V and you wish to convert it to 0 to 100% of FIELD\_VAL and -100 to 300 °C of PV, set the parameters as follows:

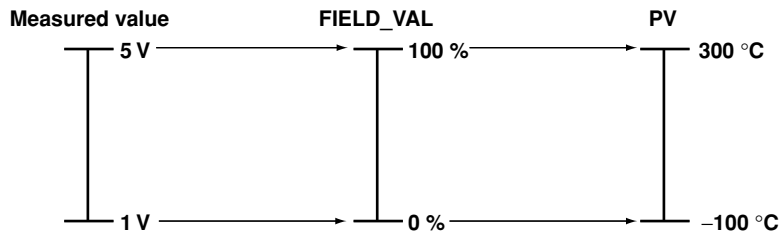

Parameter		Set value
XD_SCALE	1 EU at 100%	5
	2 EU at 0%	1
	3 Units Index	V (1240)*
	4 Decimal Point	0 (Initial value)
OUT_SCALE	1 EU at 100%	300
	2 EU at 0%	-100
	3 Units Index	°C (1001)*
	4 Decimal Point	0 (Initial value)

\* Set as necessary.

**Low Cut**

Set PV that is less than or equal to the low cut value to 0.

**Enabling/Disabling Low Cut**

You can specify whether to use low cut in IO\_OPTS. IO\_OPTS is used to specify the AI output (OUT) process. DX/MV only supports low cut.

**Parameter for Enabling/Disabling Low Cut (AI)**

Relative Index No.	Parameter	Write Mode
13	IO_OPTS	OOS

• **IO\_OPTS**

The value is a two-byte bit sequence.

**IO\_OPTS Value**

Value	Symbol	Description
Bit 10 is 1	Low Cutoff	Use low cut.
Bit 10 is 0	-	Do not use low cut.

**Setting the Low Cut Value**

**Low Cut Parameter (AI)**

Relative Index No.	Parameter	Write Mode
17	LOW_CUT	All modes

• **LOW\_CUT**

Set the low cut value to a positive value with the same engineering unit as PV or 0.

### 3.5 Setting the Function That Outputs the Measured Data (AI Function Block)

---

#### Filter

PV is smoothed through the filter.

##### Filter Parameter (AI)

Relative Index No.	Parameter	Write Mode
18	PV_FTIME	All modes

- **PV\_FTIME**  
Set the time constant of the first order delay filter in units of seconds.

#### Actions Related to OUT Status

STATUS\_OPTS specifies the actions related to Status of OUT. For details on Status, see section 5.1.

##### Parameter Related to OUT Status

Relative Index No.	Parameter	Write Mode
14	STATUS_OPTS	OOS

- **STATUS\_OPTS**  
The value is a two-byte bit sequence. The correspondence between the bits and the actions are as follows (only the used bit are indicated):

##### Parameter Value

Bit	Symbol	Description
3	Propagate Fail Forward	Even if the Status of the data from TB is "Bad, Device failure" or "Bad, Sensor failure," the data will be passed to OUT without generating an alarm.
8	Uncertain if MAN mode	When the block mode is Man or when OUT value is changed manually, "Uncertain, Non-specific, Const" is set to the Status of OUT.



## 3.6 Setting the Function That Outputs the Measured Data (MAI Function Block)

### Structure of MAI Function Block

The following figure shows the data process flow and the main parameters. For MODE\_BLK, see section 3.4.

MAI function block parameters

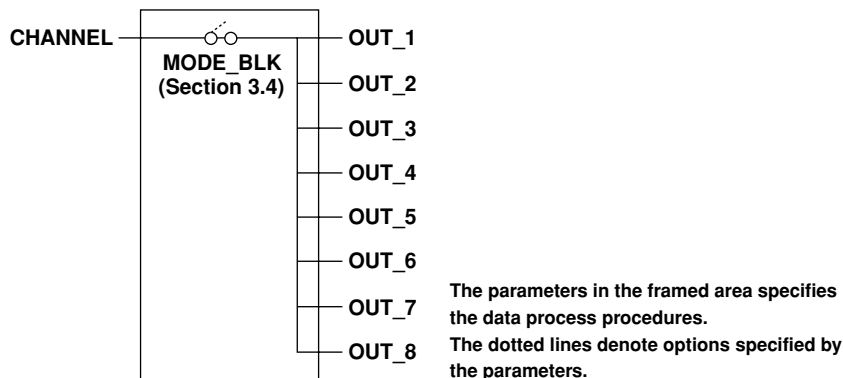

### Measured/Computed Data to Be Connected

The connection between the measured/computed data of the DX/MV and the transducer block is set using MAI\_MAP of the transducer block. In addition, the connection between the transducer block and the MAI function block is set using CHANNEL of the MAI function block (CHANNEL used by the MAI is 9).

### Setting the Connection between the Measured/Computed Data and the Transducer Block

#### Parameter for Setting the Connection (TB)

Relative Index No.	Parameter	Write Mode
14	MAI_MAP	
	1 OUT-1(MAI_MAP)	OOS
	2 OUT-2(MAI_MAP)	OOS
	3 OUT-3(MAI_MAP)	OOS
	4 OUT-4(MAI_MAP)	OOS
	5 OUT-5(MAI_MAP)	OOS
	6 OUT-6(MAI_MAP)	OOS
	7 OUT-7(MAI_MAP)	OOS
	8 OUT-8(MAI_MAP)	OOS

- **OUT-1 to OUT-8**

Sets the channel number of the DX/MV (1 through 60) to connect to OUT-1 to OUT-8.

### Connecting the Transducer Block and MAI

#### Parameter for Setting the Connection (MAI)

Relative Index No.	Parameter	Value (fixed)
7	CHANNEL	9

- **CHANNEL**

The CHANNEL value used by the MAI is 9. You cannot change this value.

## 3.7 Setting the Function That Receives Measured Data (MAO Function Block)

### Structure of MAO Function Block

The following figure shows the data process flow and the main parameters. For MODE\_BLK, see section 3.4.

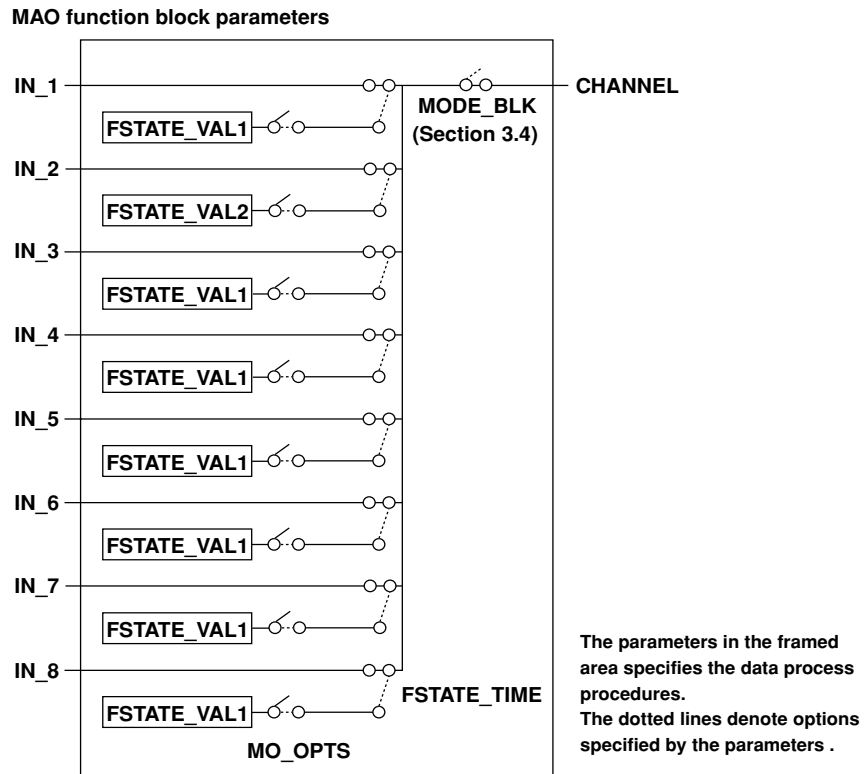

### Communication Input Data to Be Connected (C01 to C30)

The connection between the communication input data of the DX/MV and the transducer block is set using MAO\_MAP of the transducer block. In addition, the connection between the transducer block and the MAO function block is set using CHANNEL of the MAO function block (CHANNEL used by the MAO is 10).

### Setting the Connection between the Communication Input Data and the Transducer Block

#### Parameter for Setting the Connection to the Communication Input Data (TB)

Relative Index No.	Parameter	Write Mode
15	MAO_MAP	
1	IN-1 (MAO_MAP)	OOS
2	IN-2 (MAO_MAP)	OOS
3	IN-3 (MAO_MAP)	OOS
4	IN-4 (MAO_MAP)	OOS
5	IN-5 (MAO_MAP)	OOS
6	IN-6 (MAO_MAP)	OOS
7	IN-7 (MAO_MAP)	OOS
8	IN-8 (MAO_MAP)	OOS

- **IN-1 to IN-8**

Sets the communication input data number of the DX/MV (1 through 30) to connect to IN-1 to IN-8. If you specify 0, data transfer to the communication input data is not performed.

#### Connecting the Transducer Block and MAO

##### Parameter for Setting the Connection (MAO)

Relative Index No.	Parameter	Value (fixed)
7	CHANNEL	10

- **CHANNEL**

The CHANNEL value used by the MAO is 10. You cannot change this value.

#### Displaying the Communication Input Data (settings on the DX/MV)

The communication input data can be displayed on the computation channels of the DX/MV. The data is written in an equation using C01 through C12 on the DX100/MV100 and C01 through C30 on the DX200/MV200. The communication input data is in a floating-point format. However, whether the value can be used as-is (as a value with an engineering unit) depends on the device that transmitted the data. Correct the value using an equation of the DX/MV as necessary. For information on the use of the computation channel, see chapter 11 of the DX100/DX200/MV100/MV200 User's Manual.

### 3.7 Setting the Function That Receives Measured Data (MAO Function Block)

#### Output When in Fault State

When any of IN-1 to IN-8 fall into Fault State, you can have a specified value be passed to the communication input data of the DX/MV.

Fault State refers to a condition in which the data is not updated due to a disruption in communications.

#### Output When in Fault State (MAO)

Relative Index No.	Parameter	Write Mode
16	MO_OPTS	All modes
17	FSTATE_TIME	All modes
18	FSTATE_VAL1	All modes
19	FSTATE_VAL2	All modes
20	FSTATE_VAL3	All modes
21	FSTATE_VAL4	All modes
22	FSTATE_VAL5	All modes
23	FSTATE_VAL6	All modes
24	FSTATE_VAL7	All modes
25	FSTATE_VAL8	All modes
26	FSTATE_STATUS	-

- **MO\_OPTS**

Specify whether to use the function.

The value is a two-byte bit sequence. The function corresponding to the bit that is set to 1 in the following table is activated.

#### Correspondence between the Bits and Functions

Bit	Symbol	Description
0	Fault state to value 1	When in Fault State, output the specified value to the connection destination of IN-1.
1	Fault state to value 2	Same as above (for the connection destination of IN-2)
2	Fault state to value 3	Same as above (for the connection destination of IN-3)
3	Fault state to value 4	Same as above (for the connection destination of IN-4)
4	Fault state to value 5	Same as above (for the connection destination of IN-5)
5	Fault state to value 6	Same as above (for the connection destination of IN-6)
6	Fault state to value 7	Same as above (for the connection destination of IN-7)
7	Fault state to value 8	Same as above (for the connection destination of IN-8)
8	Use fault state to value on restart 1*	When restarting, output the specified value to the connection destination of IN-1.
9	Use fault state to value on restart 2	Same as above (for the connection destination of IN-2)
10	Use fault state to value on restart 3	Same as above (for the connection destination of IN-3)
11	Use fault state to value on restart 4	Same as above (for the connection destination of IN-4)
12	Use fault state to value on restart 5	Same as above (for the connection destination of IN-5)
13	Use fault state to value on restart 6	Same as above (for the connection destination of IN-6)
14	Use fault state to value on restart 7	Same as above (for the connection destination of IN-7)
15	Use fault state to value on restart 8	Same as above (for the connection destination of IN-8)

- **FSTATE\_TIME**  
Time from the point when any of IN-1 to IN-8 of MAO becomes abnormal to the point when Fault State is entered. Set the time in units of seconds.
- **FSTATE\_VAL1 to FSTATE\_VAL8**  
Values written to the communication input data of the connection destination of the DX/MV when IN-1 to IN-8 of MAO enters Fault State.
- **FSTATE\_STATUS (read only)**  
You can check whether IN-1 to IN-8 are in Fault State. The value is a one-byte bit sequence. Bit 0 to bit 7 correspond to IN-1 to IN-8 respectively. When the bit value is 1, the corresponding IN-x is in Fault State.

#### Setting Fault State/Releasing Fault State

By setting values to the following parameters, You can set IN-1 to IN-8 to Fault State at once.

##### Parameter Used to Set Fault State or Release Fault State (RB)

Relative Index No.	Parameter	Write Mode
28	FAULT_STATE	-
29	SET_FSTATE	All modes
30	CLR_FSTATE	All modes

- **SET\_FSTATE**  
If you specify "Set," IN-1 to IN-8 are automatically set to Fault State (regardless of the FSTATE\_TIME value). When Fault State is entered, the SET\_FSTATE value returns to "Off."

##### SET\_FSTATE Value

Value	Symbol	Description
1	Off	-
2	Set	Set to Fault State

- **CLR\_FSTATE**  
When you specify "Set," IN-1 to IN-8 are released from Fault State. When Fault State is released, the CLR\_FSTATE value returns to "Off."

##### CLR\_FSTATE Value

Value	Symbol	Description
1	Off	-
2	Set	Release Fault State

- **FAULT\_STATE**  
You can check whether Fault State is active (read only).

##### FAULT\_STATE Value

Value	Symbol	Description
1	Clear	Not Fault State
2	Active	Fault State

## 3.8 Setting the Trend Function (Trend Object)

### Setting the VCR and Link Object

You must set the link object and the corresponding VCR to transmit the trend. For setting the link object and VCR, see section 3.11.

### Setting the Trend Object

The DX/MV has eight Trend Objects (index numbers 32000 to 32007). Set the following four parameters for the trend object to be used.

#### Trend Object Parameter (Trend Object)

Index No.	Parameter										
32000 to 62007	Trend Float										
	<table border="1"><thead><tr><th>Sub index No.</th><th>Sub parameter</th></tr></thead><tbody><tr><td>1</td><td>Block Index</td></tr><tr><td>2</td><td>Relative Index</td></tr><tr><td>3</td><td>Sample Type</td></tr><tr><td>4</td><td>Sample Interval</td></tr></tbody></table>	Sub index No.	Sub parameter	1	Block Index	2	Relative Index	3	Sample Type	4	Sample Interval
Sub index No.	Sub parameter										
1	Block Index										
2	Relative Index										
3	Sample Type										
4	Sample Interval										

- **Block Index**  
Specify the first index number of the block with the parameter for transmitting the trend.
- **Relative Index**  
Specify the relative index number of the parameter that is to transmit the trend.
- **Sample Type**  
Specify the trend sample type using any of the following values.

#### Sample Type value

Value	Symbol	Description
1	Sample value at a time of execution	Instantaneous value.
2	Average value used between the times the value is sampled	Average value.

- **Sample Interval**  
Set the sampling interval of the trend in units of 1/32 ms. This value must be an integer multiple of the Period of Execution of the function block.

## 3.9 Setting the Function That Transmits Alerts

### Parameters Related to Alert

The following figure shows the parameters related to alert. For BLOCK\_ERR, see section 5.2. For WRITE\_LOCK, see section 3.10. For ALARM\_SUM, UPDATE\_EVT, BLOCK\_ALM, WRITE\_ALM, HI\_ALM, HI\_HI\_ALM, etc., see section 4.2. Alert status transition is explained in section 4.2.

Blocks that contains parameters

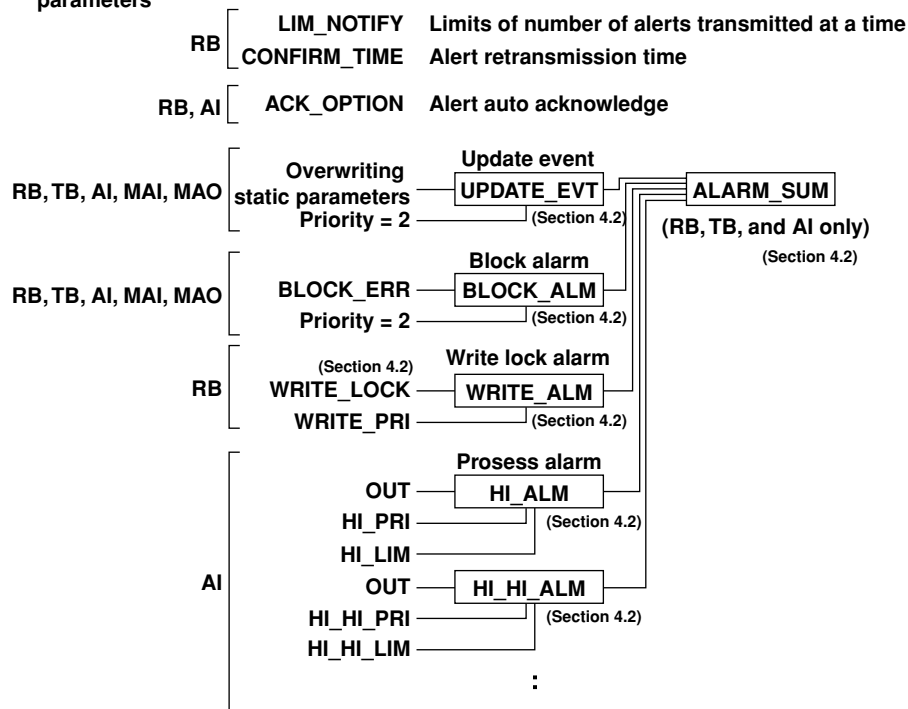

### Setting the VCR and Link Object

You must set the link object and the corresponding VCR to use the function that transmits alerts. For setting the link object and VCR, see section 3.11.

### Process Alarm (AI function block)

You can set a HI, HI\_HI, LO, and LO\_LO alarms for the OUT value. An explanation of the HI alarm is given below. Other alarms can be specified in a similar fashion.

#### HI alarm parameter (AI)

Relative Index No.	Parameter	Write Mode
24	ALARM_HYS	All modes
27	HI_PRI	All modes
28	HI_LIM	All modes

### 3.9 Setting the Function That Transmits Alerts

- **ALARM\_HYS**

Set the hysteresis for determining the alarm release in the range 0 to 50% of the span of the OUT value. Use the unit of %. This value applies to all process alarms of the particular block.

HI alarm

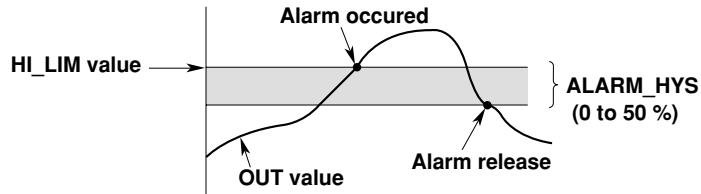

- **HI\_PRI**

Set the value to 0, 1, or 3 to 15. Transmission with a higher number is prioritized. The value 2 is reserved for block alarm and update event and cannot be used. See “Alert Priority” below.

- **HI\_LIM**

Set the alarm value using a value with the same engineering unit as the OUT value.

### Alert Priority

The following table shows the alert priority value and the corresponding actions.

**Alert Priority**

Priority <sup>*1</sup>	Value	Type of alert	Transmission	Parameter values <sup>*4</sup>
Low	0	No alert	Not	Overwritten by the newest alert
	1			
	2	Diagnostic alert <sup>*2</sup>	Transmitted	
	3 : 7	Alert caused by advisory alarm <sup>*3</sup>		
High	8 : 15	Alert caused by critical alarm <sup>*3</sup>		

\*1 Transmission with a higher number is prioritized.

\*2 The priority of the block alarm (BLOCK\_ALM) and update event (UPDATE\_EVT) is fixed to 2.

\*3 Status of I/O data indicates information on “advisory alarm” and “critical alarm.”

\*4 Indicates if the values of the following parameters are updated or not.

ALARM\_SUM, BLOCK\_ALM, WRITE\_ALM, HI\_ALM, HI\_HI\_ALM, LO\_ALM, LO\_LO\_ALM, and UPDATE\_EVT

For setting the priority of process alarms (HI\_ALM, HI\_HI\_ALM, LO\_ALM, and LO\_LO\_ALM), see “Process Alarm (AI function block).”

#### Setting the Priority of the Write Lock Alarm (WRITE\_LOCK)

The write lock alarm is transmitted when write lock is specified or released through the WRITE\_LOCK parameter.

#### Priority Parameter of the Write Lock Alarm (RB)

Relative Index No.	Parameter	Write Mode
39	WRITE_PRI	All modes



- **WRITE\_PRI**

Set the value to 0, 1, or 3 to 15. The value 2 is reserved for block alarm and update event and cannot be used.

### Limit on the Number of Alerts to Be Transmitted

LIM\_NOTIFY in the resource block is used to limit the number of alerts that can be transmitted simultaneously.

#### Parameter for Limiting the Number of Alerts That Are Transmitted simultaneously (RB)

Relative Index No.	Parameter	Write Mode
32	LIM_NOTIFY	All modes

- **LIM\_NOTIFY**

The maximum number of alerts that can be transmitted simultaneously is set using MAX\_NOTIFY (resource block, relative index number 31). It is set to 3 on the DX/MV. You can specify a value that is less than or equal to 3 for LIM\_NOTIFY.

**Note**

If you set "0" to LIM\_NOTIFY, no alert is transmitted.

### Alert Retransmission Time

The alert is retransmitted when there is no confirm message from the host in response to the alert transmission. Set the time until the alert is retransmitted using CONFIRM\_TIME in the resource block.

#### Alarm Retransmission Time Parameter (RB)

Relative Index No.	Parameter	Write Mode
33	CONFIRM_TIME	All modes

- **CONFIRM\_TIME**

Set the time from the point when an alert is transmitted until it is retransmitted in units of 1/32 ms. If you specify 0, alert retransmission is disabled.

### 3.9 Setting the Function That Transmits Alerts

#### Settings to Disable Alerts

You can disable the generation of alarms from the resource block, transducer block, and AI function block. Use the Disabled parameter of ALARM\_SUM.

##### Parameter for Disabling Alarms (RB, TB, and AI)

Relative Index No.	Parameter	Write Mode
RB: 37	ALARM_SUM	
TB: 16	1 Current	-
AI: 22	2 Unacknowledged	-
	3 Unreported	-
	4 Disabled	All modes

- **Disabled**

The value is a two-byte bit sequence. Set the bit corresponding to the alarm to be disabled to "1." The correspondence between the bits and alarms are as follows:

##### Disabled Value

Bit	Symbol	Description
0	Discrete alarm disabled	WRITE_LOCK alarm
1	High high alarm disabled	HI_HI alarm
2	High alarm disabled	HI alarm
3	Low low alarm disabled	LO_LO alarm
4	Low alarm disabled	LO alarm
5	-	Not used
6	-	Not used
7	Block alarm disabled	BLOCK alarm
8 to 15	-	(Reserved)

#### Alert Auto Acknowledge

You can have the alert automatically acknowledged even if there is no acknowledge from the host in response to the alert transmission.

##### Alert Auto Acknowledge Parameter (RB and AI)

Relative Index No.	Parameter	Write Mode
RB: 38	ACK_OPTION	All modes
AI: 23		

- **ACK\_OPTION**

The value is a two-byte bit sequence. The alert corresponding to the bit that is set to 1 is automatically acknowledged.

##### ACK\_OPTION Value

Bit	Symbol	Description
0	Discrete alarm	WRITE_LOCK alarm
1	High high alarm	HI_HI alarm
2	High alarm	HI alarm
3	Low low alarm	LO_LO alarm
4	Low alarm	LO alarm
5	-	Not used
6	-	Not used
7	Block alarm	BLOCK alarm
8 to 15	-	(Reserved)

## 3.10 Prohibiting Writing to Parameters

You can prohibit writing to all static parameters of RB, TB, AI, MAI, and MAO. The applicable parameters are those with “/S (Static)” attribute in appendix 2. The WRITE\_LOCK parameter is not applicable.

### Parameter for Prohibiting Writing to Parameters (RB)

Relative Index No.	Parameter	Write Mode
34	WRITE_LOCK	All modes

- **WRITE\_LOCK**  
Set using the following values.

### WRITE\_LOCK Value

Value	Symbol	Description
1	Unlocked	Allow writing
2	Locked	Prohibit writing

## 3.11 Setting the Communications between Function Blocks (Link Object and Virtual Communication Relationship)

You must set the link object and virtual communication relationship to perform data exchange between function blocks and transmission of alerts and trends. Setting the parameters of the link object and virtual communication relationship for each parameter individually can lead to contradictions in the operation. Thus, change the link object and virtual communication relationship per communication path collectively.

A brief explanation of the parameters of the link object and virtual communication relationship is given below.

For further information on parameters, see the specifications issued by the Fieldbus Foundation.

### Setting the Link Object

#### Link Object Parameter (Link Object)

Index No.	Parameter												
30000 to 30025	FB Link												
	<table border="1"><thead><tr><th>Sub index No.</th><th>Sub parameter</th></tr></thead><tbody><tr><td>1</td><td>Local Index</td></tr><tr><td>2</td><td>VCR Number</td></tr><tr><td>3</td><td>Remote Index</td></tr><tr><td>4</td><td>Service Operation</td></tr><tr><td>5</td><td>Stale Count Limit</td></tr></tbody></table>	Sub index No.	Sub parameter	1	Local Index	2	VCR Number	3	Remote Index	4	Service Operation	5	Stale Count Limit
Sub index No.	Sub parameter												
1	Local Index												
2	VCR Number												
3	Remote Index												
4	Service Operation												
5	Stale Count Limit												

#### Local Index

The index number of the parameter to be published or subscribed. The value is "0," when Service Operation is set to some operation other than Publisher or Subscriber.

#### VCR Number

The index number of VCR\_STATIC\_ENTRY of the VCR to be used. The same type of VCR as the service specified by Service Operation is used.

#### Remote Index

The index number of the parameter to be subscribed. The value is "0," when Service Operation is set to some operation other than Subscriber.

#### Service Operation

The value indicates the service to be used (2: Publisher, 3: Subscriber, 5: Server, 6: Alert, 7: Trend). If the link object is not to be used, the value is "0."

#### Stale Count Limit

This is the upper limit of communication attempts\* during which the value is held when the parameter cannot be subscribed continuously, in the case of subscriber communication. When this limit is exceeded, the Status of the subscribed parameter is set to Bad. The value to "0," when Service Operation is set to some operation other than Subscriber.

\* To avoid oversensitive transition of Status, we recommend that you set Stale Count Limit to a value greater than or equal to 2.

## Setting the Virtual Communication Relationship (VCR)

There are 31 virtual communication relationships on the DX/MV. The VCR is set using VCR\_STATIC\_ENTRY. VCR\_STATIC\_ENTRY 1 (index No. 293) is for system use and cannot be altered. An explanation of the VCR\_STATIC\_ENTRY 2 to 31 (index No. 294 to 323) is given below.

### Virtual Communication Relationship Parameter (MIB)

Index No.	Parameter
294 to 323	VCR_STATIC_ENTRY.2 to VCR_STATIC_ENTRY.31
1	Fas Ar Type and Role
2	Fas DII Local Addr
3	Fas DII Configured Remote Addr
4	Fas DII SDAP
5	Fas DII Max Confirm on Connect
6	Fas Max Confirm on Data
7	Fas DII Max Dlsdu Size
8	Fas DII Residual Activity Supported
9	Fas DII Timeliness Class
10	Fas DII Publisher Time Window Size
11	Fas DII Publisher Synchronizing Dlcep
12	Fas DII Subscriber Time Window Size
13	Fas DII Subscriber Synchronizing Dlcep
14	Fms Vfd Id
15	Fms Max Outstanding Service Calling
16	Fms Max Outstanding Service Called
17	Fms Features Supported

In the explanation below, the first number of the items is the subindex number.

#### 1. Fas Ar Type and Role

Type of VCR (Server, Source, Publisher, Subscriber) to be used. The value is a hexadecimal. When the VCR is not used, the value is "0."

#### 2. Fas DII Local Addr

Address used to specify the access point within the DX/MV (DLSAP address or DLCEP address).

DLSAP: Data Link Service Access point

DLCEP: Data Link Connection End point

#### 3. Fas DII Configured Remote Addr

Address used to specify the access point of the device to communicate with (DLSAP address or DLCEP address). The addresses of subindex 2 and 3 must be set to the same setting (local and remote is reversed) with the VCR of the remote device.

#### 4. Fas DII SDAP

Communication features. The value is a hexadecimal and varies depending on the communication types (Server, Source (Alert), Source (Trend), Publisher/Subscriber).

SDAP: Scheduled, Data Delivery Feature, Authentication, Priority

### 3.11 Setting the Communications between Function Blocks

---

**5. Fas DII Max Confirm Delay on Connect**

Maximum time for waiting for the response from the remote device when establishing connection. The unit is ms.

**6. Fas DII Max Confirm Delay on Data**

Maximum time for waiting for confirmation by the remote device in response to a data request. The unit is ms.

**7. Fas DII Max Dlssdu Size**

Maximum size of the data section. The unit is bytes. The value 256 is set for Server and Trend VCRs, and 64, for other VCRs (The value is determined by the value of Priority of Fas DII SDAP).

Dlssdu: Data Link Service Data Unit

**8. Fas DII Residual Activity Supported**

Specifies whether to monitor the connection. Specify true (0xff, monitor) for Server. This parameter is not used for other types of communications.

**9. Fas DII Timeliness Class**

Not used on the DX/MV.

**10.Fas DII Publisher Time Window Size**

Not used on the DX/MV.

**11.Fas DII Publisher Synchronizing Dlcep**

Not used on the DX/MV.

**12.Fas DII Subscriber Time Window Size**

Not used on the DX/MV.

**13.Fas DII Subscriber Synchronizing Dlcep**

Not used on the DX/MV.

**14.Fms Vfd Id**

Indicates the virtual field device (VFD) of the DX/MV to be used. Management Information Base VFD (the value is "0x1") or Function Block VFD (the value is "0x1234") is specified.

**15.Fms Max Outstanding Service Calling**

The value is "0" (integer) when the VCR type is Server. This parameter is not used for other types of communications.

**16.Fms Max Outstanding Service Called**

The value is "1" (integer) when the VCR type is Server. This parameter is not used for other types of communications.

**17.Fms Features Supported**

Indicates the type of service on application layer. This value is automatically set according to the application.

## 3.12 Setting the Schedule of Function Blocks

The function blocks must be executed in sync with the other blocks or the communication schedule. The following parameters are used to set the schedule.

### Schedule Parameters (MIB)

Index No.	Parameter
269	MACRO_CYCLE_DURATION
276	FB_START_ENTRY.1
	1 Start Time Offset
	2 Fb Object Index
277	FB_START_ENTRY.2
:	:
285	FB_START_ENTRY.10

- **MACRO\_CYCLE\_DURATION**

The control period of the device. The unit is 1/32 ms.

The following parameters are common to FB\_START\_ENTRY of index numbers 276 to 285.

- **Start Time Offset**

The time when the function block specified by Fb Object Index is started. It is an offset time from the start time of the macro cycle. The unit is 1/32 ms.

- **Fb Object Index**

First index number of the applicable function block.

## 3.13 Specifying Link Master Device or Basic Device

Specify whether the DX/MV is to be a link master device or a basic device.

### Parameter for Specifying Link Master Device or Basic Device (MIB)

Index No.	Parameter
367	BOOT_OPERAT_FUNCTIONAL_CLASS

- **BOOT\_OPERAT\_FUNCTIONAL\_CLASS**

### BOOT\_OPERAT\_FUNCTIONAL\_CLASS Value

Value	Symbol	Description
1	Basic	Basic device.
2	Link Master	Link master device.

When set to link master device, you must set the performance as a scheduler.



## 3.14 Setting the Node Address Range to Be Used (Link Master Function)

### Node Address Range to Be Used

The node address is used to specify a device during communication. In a fieldbus network, the address range of devices is defined as shown in the following figure.

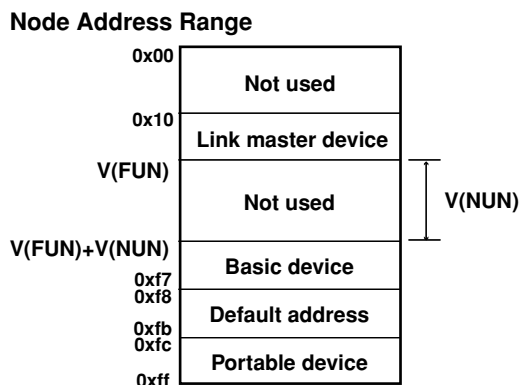

V(FUN) and V(NUN) are values for First Unpolled Node Id and Number of Consecutive Unpolled Node Id, respectively.

The range that can be specified for the devices is 16 through 247 (10 through f7 in hexadecimal notation). Normally, link master devices are assigned smaller address and basic devices are assigned larger address.

The following parameter is used to set the address range to be used.

#### Parameter for Setting the Address Range (MIB)

Index No.	Parameter
369	CONFIGURED_LINK_SETTING_RECORD
4	First Unpolled Node Id
7	Number of Consecutive Unpolled Node Id

- First Unpolled Node Id**  
 Indicates the first address of the address range that the link master device does not use.
- Number of Consecutive Unpolled Node Id**  
 Number of addresses that are not used.

The address range to be used is 10 to (V(FUN) – 1) and (V(FUN) + V(NUN)) to f7 in hexadecimal notation.

Devices that have addresses in the address range that is not used cannot participate in the fieldbus. All other address ranges are periodically checked to find new devices that are connected. To lighten the communication load of the fieldbus, keep the address range to be used small.

## 3.15 Setting the Operating Conditions of Communications (Link Master Function)

Set the following parameters.

### Communication Parameter (MIB)

Index No.	Parameter
369	CONFIGURED_LINK_SETTING_RECORD
1	Slot Time
3	Max Response Delay
6	Min Inter Pdu Delay

- **Slot Time**

Set the time required for an immediate reply of the device. The unit is octet time (256  $\mu$ s). Set the maximum value among the capability values of all devices. The DX/MV's capability value of Slot Time is 4.

- **Min Inter Pdu Delay**

Minimum value of the communication data interval. The unit is octet time (256  $\mu$ s). Set the maximum value among the capability values of all devices. The DX/MV's capability value of Min Inter Pdu Delay is 4.

- **Max Response Delay**

The worst case time until a response is received. The unit is Slot Time. The DX/MV's capability value of Max Response Delay is 3.

\* V(MRD) is the Min Inter Pdu Delay value and V(ST) is the Slot Time value.

### Example

Take the capability value\* of each device to be as shown in the following table.

\* The capability value can be confirmed by referring to the DLME\_BASIC\_INFO parameter (index number 361 (MIB) for the DX/MV).

### Device's Capability Value (DLME\_BASIC\_INFO. Bold numbers represent the worst value.)

Parameter	DX/MV	Device 1	Device 2	Device 3
1 Slot Time	4	8	10	<b>20</b>
3 Max Response Delay	3	<b>6</b>	3	5
6 Min Inter Pdu Delay	4	8	<b>12</b>	10

Set the values as follows for the DX/MV.

### Settings for the DX/MV (CONFIGURED\_LINK\_SETTING\_RECORD)

Parameter	Settings on the DX/MV
1 Slot Time	20
3 Max Response Delay	6
6 Min Inter Pdu Delay	12

## 4.1 Starting the Operation and Operations on the Host and the DX/MV

### Starting the Operation

Start the operation according to the following steps.

#### Steps to start operation

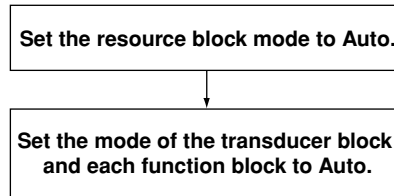

#### Setting the Resource Block Mode

1. Set the resource block mode to Auto. If the resource block is not set to Auto, the resources controlled by the resource block cannot be used and other blocks cannot shift to modes other than OOS.  
For the procedure in changing the mode, see section 3.4. For information on the parameter that indicates the state of the resource block (RS\_STATE), see section 5.2.

#### Setting the Mode of the Transducer Block and Function Blocks

2. Set the mode of the transducer block, AI, MAI, and MAO function blocks to Auto.  
For the procedure in changing the mode, see section 3.4.

### Operations on the Host

Operations are carried out on the host. The operation varies depending on the host. See the user's manual of the host that you are using.

This chapter explains how to change the block mode, how to check the alert, how to use the simulation function of the AI function block, and the relevant parameters.

### Operations on the DX/MV

On the DX/MV, you can check the Status of the data received from other devices at the MAO function block on the FIELDBUS DATA screen.

For operations of the DX/MV other than the FIELDBUS DATA screen, see the DX100/DX200/MV100/MV200 User's Manual.

## 4.2 Handling Alerts

### Transmitting Responses

When an alert message is received, the host should return an response message. The DX/MV retransmits the alert until the confirm message from the host is received (see section 3.9). The alert status transits as shown in the figure below. You can check the alert status by the parameters explained here. If alarms or update events occur before the alert status cycle completes, the parameters are overwritten by the newest alarm or update event status.

#### Alert Status Transition

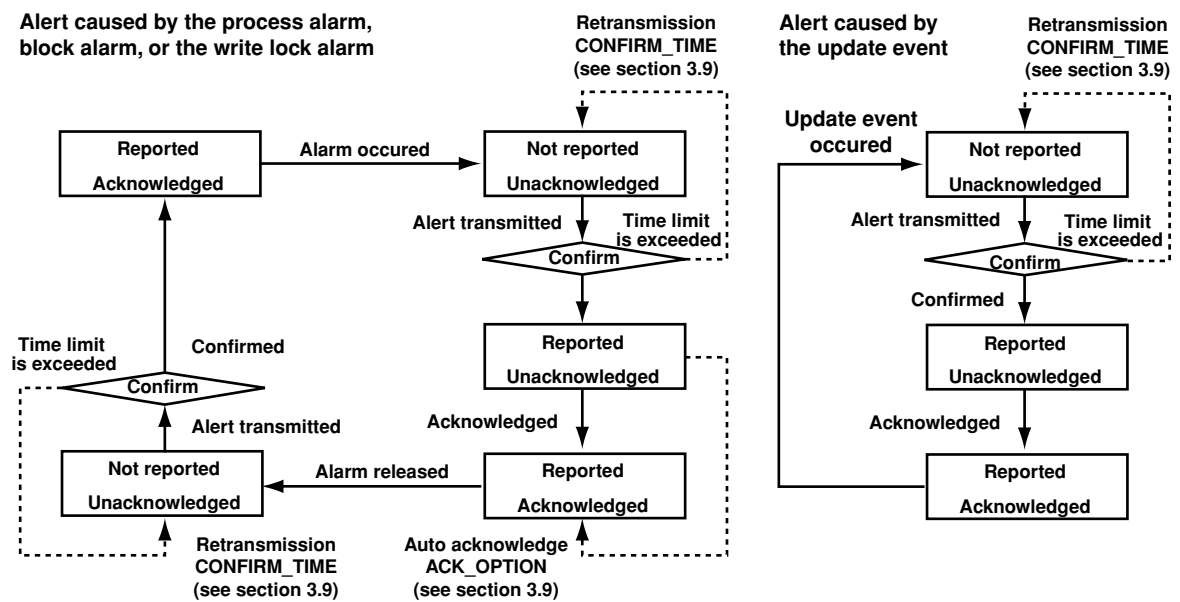

### Checking the State of the Process Alarm (AI)

The alarm state of HI, HI\_HI, LO, and LO\_LO alarms can be checked through the following parameter. Enclosed in parentheses is the relative index number.

HI alarm: HI\_ALM (34), HI\_HI alarm: HI\_HI\_ALM (33)  
 LO alarm: LO\_ALM (35), LO\_LO alarm: LO\_LO\_ALM (36)

The HI\_ALM is explained here. Other alarms can be checked in a similar fashion.

#### HI Alarm Parameter (AI)

Relative Index	Parameter	Description (Value: Symbol)
34	HI_ALM	
1	Unacknowledged	Presence or absence of an acknowledge message 1: Acknowledged (can be written) 2: Unacknowledged
2	Alarm State	Alarm state 1: Clear-reported (Alarm release transmitted) 2: Clear-not reported (Waiting to transmit alarm release) 3: Active-reported (Alarm occurrence transmitted) 4: Active-not reported (Waiting to transmit alarm occurrence)
3	Time Stamp	Time when the alarm was detected
4	Subcode	Not used
5	Value	OUT value when the alarm occurred

## Checking the State of the Block Alarm (RB, TB, AI, MAI, MAO)

### Checking the Alarm State

You can check the block alarm state through BLOCK\_ALM of each block.

#### Block Alarm Parameter (RB, TB, AI, MAI, and MAO)

Relative Index	Parameter	Description (Value: Symbol)
RB: 36	BLOCK_ALM	
TB: 8 AI: 21 MAI: 17	1 Unacknowledged	Presence or absence of an acknowledge message 1: Acknowledged (can be written) 2: Unacknowledged
MAO: 28	2 Alarm State	Alarm state 1: Clear-reported (Alarm release transmitted) 2: Clear-not reported (Waiting to transmit alarm release) 3: Active-reported (Alarm occurrence transmitted) 4: Active-not reported (Waiting to transmit alarm occurrence)
	3 Time Stamp	Time when the alarm was detected
	4 Subcode	BLOCK_ERR value
	5 Value	Not used

### Checking the Alarm Information

You can check the alarm information through the BLOCK\_ERR value of each block. For details on the BLOCK\_ERR values, see section 5.2.

#### Parameter Indicating the Block Alarm Information (RB, TB, AI, MAI, and MAO)

Relative Index	Parameter
6	BLOCK_ERR

## Checking the State of the Write Lock Alarm

You can check the state of the write lock alarm through WRITE\_ALM of the resource block.

#### Write Lock Alarm Parameter (RB)

Relative Index	Parameter	Description (Value: Symbol)
40	WRITE_ALM	
	1 Unacknowledged	Presence or absence of an acknowledge message 1: Acknowledged 2: Unacknowledged
	2 Update State	Write lock alarm state 1: Clear-reported (Write lock release transmitted) 2: Clear-not reported (Waiting to transmit write lock release) 3: Active-reported (Write lock enable transmitted) 4: Active-not reported (Waiting to transmit write lock enable)
	3 Time Stamp	Time when the write lock alarm occurred
	4 Subcode	Not used
	5 Value	WRITE_LOCK value when the write lock alarm occurred

### Checking the State of the Update Event

You can check the state of the update event through UPDATE\_EVT of each block. While the block mode is OOS (the value of Actual of MODE\_BLK is OOS), no alert will be transmitted even if the parameters are written. The retained alert will be transmitted when the block goes out of OOS mode.

#### Update Event Parameter (RB, TB, AI, MAI, and MAO)

Relative Index	Parameter	Description (Value: Symbol)
RB: 35	UPDATE_EVT	
TB: 7 AI: 20 MAI: 16	1 Unacknowledged	Presence or absence of an acknowledge message 1: Acknowledged (can be written) 2: Unacknowledged
MAO: 27	2 Update State	Update event state 1: Update-reported (Update event transmitted) 2: Update-not reported (Waiting to transmit update event)
	3 Time Stamp	Time when the update event occurred
	4 Static Revision	Revision value of the static parameter when the update event occurred (ST_REV value)
	5 Relative Index	Relative index number of the updated parameter. However, the value is set to 0 when an update event occurs as a result of updating multiple parameters simultaneously.

### Checking through the Alarm Summary

You can check the state of all the alarms of the RB, TB, or AI function block through ALARM\_SUM of each block.

#### Alarm Summary Parameter (RB, TB, and AI)

Relative Index	Parameter	Description (Value: Symbol)
RB: 37	ALARM_SUM	
TB: 16	1 Current	Indicates the alarm that is currently occurring
AI: 22	2 Unacknowledged	Indicates the alarms that have not received an acknowledge message from the host in response to the alarm transmission
	3 Unreported	Indicates the alarms which have not been transmitted
	4 Disabled	Sets whether to generate the alarm (see section 3.9)

The alarm type is indicated using a two-byte bit sequence. The alarm corresponding to the bit that is set to 1 is the alarm that meets the above conditions.

#### ALARM\_SUM Value

Bit	Symbol	Description
0	Discrete alarm	WRITE_LOCK
1	High high alarm	HI_HI_ALM
2	High alarm	HI_ALM
3	Low low alarm	LO_LO_ALM
4	Low alarm	LO_ALM
5	-	Not used
6	-	Not used
7	Block alarm	BLOCK_ALM
8 to 15	-	(Reserved)

## 4.3 Using the Simulation Function (AI Function Block)

The AI function block is capable of outputting a manually specified value in place of the actual value from the sensor.

When the simulation function is not in use, the value received from the transducer block is transmitted to FIELD\_VAL and PV through SIMULATE.

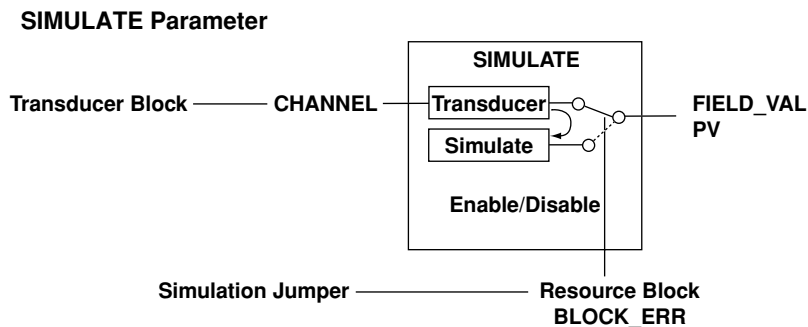

### Turning ON the Simulation Jumper

To use the simulation function, turn ON the Simulation Jumper. A block alarm is generated from the resource block (Simulate Active (bit 3) of the BLOCK\_ERR parameter is set to 1) and the simulation function is enabled.

There are two methods in turning ON the Simulation Jumper.

#### Turning ON the SimEnable Terminal

Short the SimEnable terminal on the rear panel of the DX/MV and the FG terminal. For details on the SimEnable terminal, see section 2.2.

#### Using the SIM\_ENABLE\_MSG Parameter

##### Parameter for Turning ON the Simulation Jumper (RB)

Relative Index	Parameter	Write Mode
44	SIM_ENABLE_MSG	All modes

Specifying “REMOTE\_LOOP\_TEST\_SWITCH” (all capitals, “\_” indicates a space) to this parameter turns ON the Simulation Jumper. However, this setting is lost when the power is turned OFF.

### 4.3 Using the Simulation Function (AI Function Block)

---

#### Outputting Simulation Values

##### Setting Whether to Output Simulation Values

Set whether to output simulation values through Enable/Disable of SIMULATE of the AI function block.

##### Parameter for Setting the Simulation (AI)

Relative Index	Parameter	Description (Value: Meaning)
9	SIMULATE	
	1 Simulate Status	Status value* when simulation is enabled
	2 Simulate Value	Process value when simulation is enabled
	3 Transducer Status	Status value from the transducer block. You cannot change this value.
	4 Transducer Value	Process value from the transducer block. You cannot change this value.
5 Enable/Disable	Controls the enable/disable of the simulation 1: Simulation disabled 2: Simulation enabled	

\* For details on the status values, see section 5.1.

##### Setting the Simulation Value

Simulation value is set through SIMULATE of the AI function block. The relationship between the specified simulation value and the output value is expressed by the equation given in "Process Procedure of the Measured/Computed Data" in section 3.5.

##### Note

- The specified simulation value can only be output when the simulation jumper is ON and Enable/Disable of SIMULATE is set to 2 (Enable). If this condition is not satisfied, the value from the resource block is output.
  - When the simulation function is not used, the values from the transducer block are copied to Simulation Value and Simulation Status.
-



## 4.4 Checking the Status of the Communication Input Data

The PD tag, node address, and the status of the process value that the MAO function block of the DX/MV has retrieved from the fieldbus can be confirmed on the FIELDBUS DATA screen of the DX/MV.

### FIELDBUS DATA Screen

For the items displayed at Quality, Sub-status, and Limit and their meanings, see “Status and Value of the Input Parameter” in section 5.1.

PD Tag : DAQSTATION				PD tag of the DX/MV
Node Address : 245				
Comm CH	Quality	Sub-status	Limit	
C01	Good(NC)	Non-specific	Not limited	

Quality sub status (see section 5.1) Limit (see section 5.1)  
 Quality of the communication data (see section 5.1)  
 Communication input data that is linked (see section 3.7)

### Procedure in Displaying the Status Screen

1. Press the FUNC key of the DX/MV. The FUNC menu appears.
2. Press the Fieldbus soft key. The FIELDBUS DATA screen appears.



## 5.1 Handling the I/O Status

When correct data are not displayed on the DX/MV or the host, the cause can be identified by checking the data processing process one by one in the reverse order to the publisher. In that case, Status of I/O parameters has useful information. For how to use Status of I/O parameters, see an example on the latter part of this section.

### I/O Parameter Status

#### Applicable Parameters

The following parameters have two values, Status and Value.

Parameter	Description
PV	AI-1 through AI-8 function blocks
OUT	AI-1 through AI-8 function blocks
SIMULATE	AI-1 through AI-8 function blocks The following parameters of SIMULATE • Simulate Status, Simulate Value • Transducer Status, Transducer Value
FIELD_VAL	AI-1 through AI-8 function blocks
OUT-1 to OUT-8	MAI function block
IN-1 to IN-8	MAO function block

#### Status Structure

Status consists of Quality, Quality Sub-status, and Limit. It indicates the status of Value. Status uses the 8 bits as shown in the following figure and expresses the quality of the data with the values.

#### Status Structure

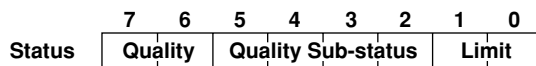

#### Value and Meaning of Quality and Quality Sub-status

Quality and Quality Sub-status have the following values and meanings. The values and meanings that the I/O parameters of the DX/MV can have, and corrective action to them, see pages 5-4 and 5-5.

Quality Value	Quality Indication (Top Row) and Meaning (Bottom Row)
0	Bad Value is invalid.
Sub-status Value	Sub-status Indication (Top Row) and Meaning (Bottom Row)
0	Non-specific The cause cannot be determined.
1	Configuration Error A problem exists in the FB.
2	Not Connected No connection to the input.
3	Device Failure The value is influenced by device failure.
4	Sensor Failure The value has exceeded the limits of the device.
5	No communication, with last usable value Failed to communicate the value.
6	No communication, with no usable value No value has been communicated after the last OOS.
7	Out of Service The value is unreliable because the FB is not operating.

## 5.1 Handling the I/O Status

Quality Value	Quality Indication (Top Row) and Meaning (Bottom Row)
1	Uncertain The quality of Value is inferior as compared to the normal case, but it may be used.
	<b>Sub-status Value    Sub-status Indication (Top Row) and Meaning (Bottom Row)</b>
0	Non-specific The cause cannot be determined.
1	Last Usable Value* The remote device that was writing the value stopped the operation.
2	Substitute The value was written when the FB was not OOS.
3	Initial Value The input has not changed since the value was written when the FB was OOS.
4	Sensor Conversion not Accurate The value has exceeded the limits of the sensor or the precision of the sensor is not appropriate.
5	Engineering Unit Range Violation The value has exceeded the range of values that has been defined with an engineering unit.
6	Sub-normal Value that has been generated without the required number of information.

\* This occurs when the input is disconnected by the configurator.

Quality Value	Quality Indication (Top Row) and Meaning (Bottom Row)
2	Good (Non-Cascade) Value is invalid.
	<b>Sub-status Value    Sub-status Indication (Top Row) and Meaning (Bottom Row)</b>
0	Non-specific The cause cannot be determined.
1	Active Block Alarm An active block alarm exists.
2	Active Advisory Alarm An alarm with a priority less than 8 is occurring.
3	Active Critical Alarm An alarm with a priority greater than or equal to 8 is occurring.
4	Unacknowledged Block Alarm A block alarm that has not received an acknowledge message from the host exists.
5	Unacknowledged Advisory Alarm An alarm with a priority less than 8 that has not received an acknowledge from the host exists.
6	Unacknowledged Critical Alarm An alarm with a priority greater than or equal to 8 that has not received an acknowledge from the host exists.

Quality Value	Quality Indication (Top Row) and Meaning (Bottom Row)
3	Good (Cascade) Value is valid and can be used for control.
Sub-status Value	Sub-status Indication (Top Row) and Meaning (Bottom Row)
0	Non-specific The cause cannot be determined.
1	Initialization Acknowledged (IA) The value is set to the initial value on the source side.
2	Initialization Request (IR)* The value is set to the initial value on the source side.
3	Not Invited (NI) Value from the FB that is not looping back this input.
4	Not Selected (NS) Value from the selected Control Selector that is not looping back this input.
5	= Reserved 6 = Local Override (LO) Value that has been overwritten by the internal logic of the FB.
7	Fault State Active (FSA) Value from the FB of which Fault State is Active.
8	Initial Fault State (IFS) Value from the FB that is requesting the FB on the data receiving side to become "Fault State."

\* This occurs when the downstream side of the control loop is disconnected.

#### Value and Meaning of Limit

Limit Value	Limit Indication (Top Row) and Meaning (Bottom Row)
0	Not limited The value can change freely.
1	Low limited There is a lower limit placed on the value.
2	High limited There is an upper limit placed on the value.
3	Constant (high and low limited) The value cannot change.

## 5.1 Handling the I/O Status

### OUT (AI) Status and Corrective Actions

Quality	Sub status	Limit	Cause	Corrective Action/Reference Section
Bad	Non-specific	Not limited	The RB is in OOS mode. EEPROM failure	3.4 Check DEVICE_STATUS (section 5.3).
Bad	Configuration Error	Not limited	The connected channel is not correct. The connected channel is skipped.	Check AI_MAP value (section 3.5), or see chapters 5 and 11 of the DX/MV's User's Manual. See chapter 5 of the DX/MV's User's Manual.
Bad	Device Failure	Not limited	Internal error	Check DEVICE_STATUS (section 5.3).
Bad	Sensor Failure	Not limited	The sensor has burned out. Error data Invalid data	Check the sensor. See chapters 5 and 11 of the DX/MV's User's Manual. See chapters 5 and 11 of the DX/MV's User's Manual.
		High	Positive overrange, positive computation overflow	See chapters 5 and 11 of the DX/MV's User's Manual.
		Low	Negative overrange, negative computation overflow	See chapters 5 and 11 of the DX/MV's User's Manual.
Bad	Out of Service	Not limited	TB or AI is in OOS mode.	3.4
Good (Non-Cascade)	Non-specific	Not limited	Data is valid	
Good (Non-Cascade)	Active Block Alarm	Not limited	Data is valid	An active block alarm exists. 4.2
Good (Non-Cascade)	Active Advisory Alarm	Not limited	Data is valid	Alarm with a priority less than 8 is occurring. 4.2
Good (Non-Cascade)	Active Critical Alarm	Not limited	Data is valid	Alarm with a priority greater than or equal to 8 is occurring. 4.2
Good (Non-Cascade)	Unacknowledged Block Alarm	Not limited	Data is valid	A block alarm that has not received an acknowledge message from the host exists. 4.2
Good (Non-Cascade)	Unacknowledged Advisory Alarm	Not limited	Data is valid	An alarm with a priority less than 8 that has not received an acknowledge from the host exists. 4.2
Good (Non-Cascade)	Unacknowledged Critical Alarm	Not limited	Data is valid	An alarm with a priority greater than or equal to 8 that has not received an acknowledge from the host exists. 4.2

**FIELD\_VAL (AI) Status and Corrective Actions**

Quality	Sub status	Limit	Cause	Corrective Action/Reference Section
Bad	Non-specific	Not limited	The RB is in OOS mode. EEPROM failure	3.4 Check DEVICE_STATUS (section 5.3).
Bad	Configuration Error	Not limited	The connected channel is not correct. The connected channel is skipped.	Check AI_MAP value (section 3.5), or see chapters 5 and 11 of the DX/MV's User's Manual. See chapter 5 of the DX/MV's User's Manual.
Bad	Device Failure	Not limited	Internal error	Check DEVICE_STATUS (section 5.3).
Bad	Sensor Failure	Not limited	The sensor has burned out. Error data Invalid data	Check the sensor. See chapters 5 and 11 of the DX/MV's User's Manual. See chapters 5 and 11 of the DX/MV's User's Manual.
		High	Positive overrange, positive computation overflow	See chapters 5 and 11 of the DX/MV's User's Manual.
		Low	Negative overrange, negative computation overflow	See chapters 5 and 11 of the DX/MV's User's Manual.
Bad	Out of Service	Not limited	TB or AI is in OOS mode.	3.4
Good (Non-Cascade) Non-specific		Not limited	Data is valid	

**Status of OUT\_1 through OUT\_8 (MAI) and Corrective Actions**

Quality	Sub status	Limit	Cause	Corrective Action/Reference Section
Bad	Non-specific	Not limited	The RB is in OOS mode. EEPROM failure	3.4 Check DEVICE_STATUS (section 5.3).
Bad	Configuration Error	Not limited	The connected channel is not correct. The connected channel is skipped.	See chapters 5 and 11 of the DX/MV's User's Manual. See chapter 5 of the DX/MV's User's Manual.
Bad	Device Failure	Not limited	Internal error	Check DEVICE_STATUS (section 5.3).
Bad	Sensor Failure	Not limited	The sensor has burned out. Error data Invalid data	Check the sensor. See chapters 5 and 11 of the DX/MV's User's Manual. See chapters 5 and 11 of the DX/MV's User's Manual.
		High	Positive overrange, positive computation overflow	See chapters 5 and 11 of the DX/MV's User's Manual.
		Low	Negative overrange, negative computation overflow	See chapters 5 and 11 of the DX/MV's User's Manual.
Bad	Out of Service	Not limited	TB or AI is in OOS mode.	3.4
Good (Non-Cascade) Non-specific		Not limited	Data is valid	
Good (Non-Cascade) Active Block Alarm		Not limited	Data is valid	An active block alarm exists. 4.2
Good (Non-Cascade) Unacknowledged Block Alarm		Not limited	Data is valid	A block alarm that has not received an acknowledge message from the host exists. 4.2

**Status of IN-1 through IN-8 (MAO)**

IN-1 through IN-8 are data that is received externally. Determine the quality of the data by referring to the value and meaning of Quality and Quality Sub-status in the “Input Parameter Status” section.

**Value of Input/Output Parameters**

Value is a floating-point decimal that can take on the values in the range in the white area in the following figure. In addition to this range, there is also a range of values that the measurement and computation channels of the DX/MV can handle. For information on this range, see the DX/MV’s User’s Manual.

If the value on the measurement channel becomes  $\pm$ overrange or the value on the computation channel becomes  $\pm$ over display range in the processing of the DX/MV, the value  $\pm$ OVER ( $\pm 1.0E+37$ ) is passed to the transducer block.

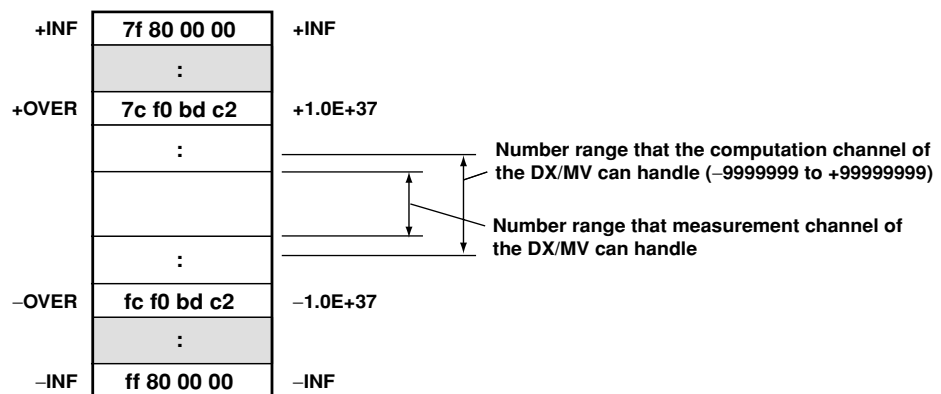

## An Example Explaining How to Use Status of I/O Parameters

The figure shows the case in which the data retrieved from AI function block OUT of the DX/MV is erroneous.

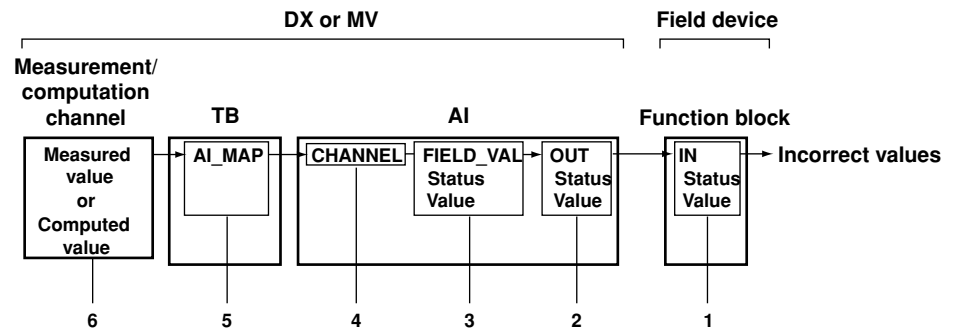

Start from the step No.1 in the figure. If the cause is not identified, go to the next step.

### 1. Checking Value and Status of IN of the field device

See the user's manual for the field device.

### 2. Checking Value and Status of AI function block OUT

- **Status is "Good (Non-Cascade)"**

If the Status is "Good (Non-Cascade)" and the Value is correct, the problem exists after the AI function block (communication via fieldbus in this case).

- **Status is "Bad"**

If the Status is "Bad," check the information through the Sub-Status value.

- **Status is "Bad" and Sub-Status is "Non-specific"**

The resource block is not set to Auto mode. Set the block mode of the resource block to Auto (see section 3.4).

- **Status is "Bad" and Sub-Status is "Sensor Failure" and Limit is "High"**

If the AI function block OUT is connected to the measurement channel of the DX/MV, positive over range is occurring. Check the input signal to the measurement channel.

If the AI function block OUT is connected to the computation channel of the DX/MV, positive over display range is occurring. Check the equation or the data used in the equation.

Check the Sub-Status and Limit value in the similar fashion as described above, and take proper corrective actions.

### 3. Checking Value and Status of AI function block FIELD\_VAL

- **Status is "Good (Non-Cascade)"**

If the Status is "Good (Non-Cascade)" and the Value is correct, the problem exists in the data processing after FIELD\_VAL.

- **Status is "Bad"**

If the Status is "Bad," check the information through the Sub-Status value.

- **Status is "Bad" and Sub-Status is "Non-specific"**

The resource block is not set to Auto mode. Set the block mode of the resource block to Auto (see section 3.4).

Check the Sub-Status and Limit value in the similar fashion as described above, and take proper corrective actions.

### 4., 5., 6.

Check the settings of CHANNEL of the AI function block, AI\_MAP of the transducer block, and the measurement/computation channel.



## 5.2 Handling Block Errors

You can check the cause of the block alarm of a function block through BLOCK\_ERR of each block. For the transducer block, also check the XD\_ERROR value, which indicates “transducer” \* error.

\* Transducers are components of the transducer block.

### Parameter Indicating Block Error (RB, TB, AI, MAI, and MAO)

Relative Index No.	Parameter
6	BLOCK_ERR

### Parameter Indicating the Information of the Transducer Error (TB)

Relative Index No.	Parameter
11	XD_ERROR

BLOCK\_ERR information is expressed using a two-byte bit sequence. The block alarm corresponding to the bit that is set to 1 is occurring. The cause of the block alarm of each function block is shown below.

### Resource Block

Only the used bits are indicated.

#### BLOCK\_ERR Value and Corrective Action

Bit	Indication	Description	Corrective Action/Reference Section
3	Simulate Active	Simulation Jumper is ON	4.3
5	Device Fault State Set	FAULT_STATE of the RB is active	3.7
10	Lost Static Data	Internal error	Check DEVICE_STATUS (section 5.3).
11	Lost NV Data	Internal error	Check DEVICE_STATUS (section 5.3).
13	Device Needs Maintenance Now	Internal error	Check DEVICE_STATUS (section 5.3).
15	Out of Service	RS_STATE is not “Online,” or Target. MODE_BLK is OOS.	3.4 and “States and Transition of the Resource Block” in this section

### Transducer Block

Only the used bits are indicated.

#### BLOCK\_ERR Value and Corrective Action

Bit	Indication	Description	Corrective Action/Reference Section
7	Input Failure	Internal error	Check DEVICE_STATUS (section 5.3).
8	Output Failure	Internal error	Check DEVICE_STATUS (section 5.3).
13	Device Needs Maintenance Now	Internal error	Check DEVICE_STATUS (section 5.3).
15	Out of Service	RS_STATE is not “Online,” or Target. MODE_BLK is OOS.	3.4 and “States and Transition of the Resource Block” in this section

XD\_ERROR takes the following values.

#### XD\_ERROR Value and Corrective Action

Value	Indication	Description	Corrective Action/Reference Section
20	Electronic failure	Internal error	Check DEVICE_STATUS (section 5.3).
22	I/O failure	Internal error	Check DEVICE_STATUS (section 5.3).

### AI Function Block

Only the used bits are indicated.

#### BLOCK\_ERR Value and Corrective Action

Bit	Indication	Description	Corrective Action/Reference Section
1	Block Configuration Error	The CHANNEL value of the FB is not correct.	3.4
3	Simulate Active	Simulate Enable/Disable of SIMULATE of the AI is set to Enable	4.3
7	Input Failure	Internal error	Check DEVICE_STATUS (section 5.3).
15	Out of Service	The MODE_BLK Target of the RB or AI is OOS.	3.4

### MAI Function Block

Only the used bits are indicated.

#### BLOCK\_ERR Value and Corrective Action

Bit	Indication	Description	Corrective Action/Reference Section
1	Block Configuration Error	The CHANNEL value of the FB is not correct.	3.6
7	Input Failure	Internal error	Check DEVICE_STATUS (section 5.3).
15	Out of Service	The MODE_BLK Target of the RB or MAI is OOS.	3.4

### MAO Function Block

Only the used bits are indicated.

#### BLOCK\_ERR Value and Corrective Action

Bit	Indication	Description	Corrective Action/Reference Section
1	Block Configuration Error	The CHANNEL value of the FB is not correct.	3.6
4	Local Override	Actual of MODE_BLK of the MAO is Local Override (LO).	Fault State condition. 3.4 and 3.7
8	Output Failure	Internal error	Check DEVICE_STATUS (section 5.3).
15	Out of Service	The MODE_BLK Target of the RB or MAO is OOS.	3.4

### States and Transition of the Resource Block

The following figure shows the various states of the resource block.

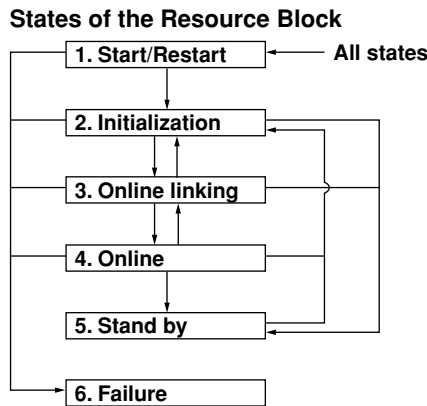

#### Start/Restart

This is the state at the time the DX/MV is started or restarted. An initial check is executed, and upon success, transition is made to Initialization.

#### Initialization

The node address is not specified in this state. The function block does not operate. When the node address is set and the block mode is set to Auto, transition is made to Online or Online linking state.

When the node address is set and the block mode is set to OOS, transition is made to Stand by.

#### Online linking

This is the state in which the block mode is set to Auto and the block mode is running automatically. However, there is one or more VCRs used in the communication that are not opened, and their links are not established. When the link is established, the transition is made to Online.

If the node address is cleared, the state returns to Initialization.

#### Online

This is the state in which the block mode is set to Auto and the block is running automatically.

If the node address is cleared, the state returns to Initialization.

#### Stand by

This is the state in which the block mode is OOS, and the resource block is in a state other than Failure. When the block mode is set to Auto, transition is made to Initialization, Online linking, or Online.

#### Failure

If the result of self diagnosis in any state is failure, transition is made to Failure. After transmitting a block alarm, the parameters of all function blocks are reset to their initial values. The DX/MV has malfunctioned.

### Checking the State of the Resource Block

The RS\_STATE parameter of the resource block can be used to check the state of the resource block.

#### Parameter That Indicates the State of the Resource Block (RB)

Relative Index No.	Parameter	Description
7	RS_STATE	The state is indicated using an 8-bit unsigned integer (read only).

The correspondence between the bits and states are as follows:

#### RS\_STATE Value

Value	State
1	Start/Restart
2	Initialization
3	Online linking
4	Online
5	Stand by
6	Failure

## 5.3 Handling the Device Status (DEVICE\_STATUS)

### Displaying the Status

You can check the status of the DX/MV through DEVICE\_STATUS\_1 to DEVICE\_STATUS\_8 of the resource block.

#### Parameter for Confirming the DX/MV Status (RB)

Relative Index No.	Parameter	Description
45	DEVICE_STATUS_1	Status of the RB and VCR
46	DEVICE_STATUS_2	Status of the TB and the identification information of the DX/MV
47	DEVICE_STATUS_3	Status of AI-1 to AI-8
48	DEVICE_STATUS_4	Status of the MAI
49	DEVICE_STATUS_5	Status of the MAO
50	DEVICE_STATUS_6	Not used
51	DEVICE_STATUS_7	Not used
52	DEVICE_STATUS_8	Not used

The value of each parameter is a four-byte bit sequence. The correspondence between the bits and statuses and the corrective actions are shown below. When the bit value is 1, the DX/MV is in the described status.

### DEVICE\_STATUS\_1

Only the used bits are indicated.

#### DEVICE\_STATUS\_1 Value and Corrective Action

Bit	Indication	Description	Corrective Action/Reference Section
23	Sim.enable Jmpr On	Simulation Jumper is ON	4.3
22	RB in OOS mode	MODE_BLK.ACTUAL of the RB is OOS	3.4
19	EEPROM failure	Problems in the non-volatile memory (EEPROM).	Contact your nearest YOKOGAWA dealer.
15	Link Obj.1/17 not open	The VCR corresponding to the VCR Number of the Link Object is not open.	3.11
14	Link Obj.2/18 not open	Same as above	Same as above
13	Link Obj.3/19 not open	Same as above	Same as above
12	Link Obj.4/20 not open	Same as above	Same as above
11	Link Obj.5/21 not open	Same as above	Same as above
10	Link Obj.6/22 not open	Same as above	Same as above
9	Link Obj.7/23 not open	Same as above	Same as above
8	Link Obj.8/24 not open	Same as above	Same as above
7	Link Obj.9/25 not open	Same as above	Same as above
6	Link Obj.10/26 not open	Same as above	Same as above
5	Link Obj.11/27 not open	Same as above	Same as above
4	Link Obj.12/28 not open	Same as above	Same as above
3	Link Obj.13/29 not open	Same as above	Same as above
2	Link Obj.14/30 not open	Same as above	Same as above
1	Link Obj.15/31 not open	Same as above	Same as above
0	Link Obj.16/32 not open	Same as above	Same as above

**DEVICE\_STATUS\_2**

Only the used bits are indicated.

**DEVICE\_STATUS\_2 Value and Corrective Action**

Bit	Indication	Description	Corrective Action/Reference Section
30	DEVICE_ID failure	Invalid DEVICE_ID.	Contact your nearest YOKOGAWA dealer.
29	REVISION failure	Invalid DEV_TYPE, DEV_REV, or DD_REV.	Contact your nearest YOKOGAWA dealer.
28	UART failure	Problems in the internal communication (UART).	Contact your nearest YOKOGAWA dealer.
15	TB in O/S mode	MODE_BLK.ACTUAL of the TB is OOS.	3.4

**DEVICE\_STATUS\_3**

Only the used bits are indicated.

**DEVICE\_STATUS\_3 Value and Corrective Action**

Bit	Indication	Description	Corrective Action/Reference Section
30	AI-1 in O/S mode	MODE_BLK.ACTUAL of AI-1 is OOS.	3.4
29	AI-2 in O/S mode	MODE_BLK.ACTUAL of AI-2 is OOS.	3.4
28	AI-3 in O/S mode	MODE_BLK.ACTUAL of AI-3 is OOS.	3.4
27	AI-4 in O/S mode	MODE_BLK.ACTUAL of AI-4 is OOS.	3.4
26	AI-5 in O/S mode	MODE_BLK.ACTUAL of AI-5 is OOS.	3.4
25	AI-6 in O/S mode	MODE_BLK.ACTUAL of AI-6 is OOS.	3.4
24	AI-7 in O/S mode	MODE_BLK.ACTUAL of AI-7 is OOS.	3.4
23	AI-8 in O/S mode	MODE_BLK.ACTUAL of AI-8 is OOS.	3.4
15	AI-1 not scheduled	AI-1 is not scheduled.	3.12
14	AI-2 not scheduled	AI-2 is not scheduled.	3.12
13	AI-3 not scheduled	AI-3 is not scheduled.	3.12
12	AI-4 not scheduled	AI-4 is not scheduled.	3.12
11	AI-5 not scheduled	AI-5 is not scheduled.	3.12
10	AI-6 not scheduled	AI-6 is not scheduled.	3.12
9	AI-7 not scheduled	AI-7 is not scheduled.	3.12
8	AI-8 not scheduled	AI-8 is not scheduled.	3.12

**DEVICE\_STATUS\_4**

Only the used bits are indicated.

**DEVICE\_STATUS\_4 Value and Corrective Action**

Bit	Indication	Description	Corrective Action/Reference Section
30	MAI-1 in O/S mode	MODE_BLK.ACTUAL of MAI-1 is OOS.	3.4
15	MAI-1 not scheduled	MAI-1 is not scheduled.	3.12

**DEVICE\_STATUS\_5**

Only the used bits are indicated.

**DEVICE\_STATUS\_5 Value and Corrective Action**

Bit	Indication	Description	Corrective Action/Reference Section
30	MAO-1 in O/S mode	MODE_BLK.ACTUAL of MAO-1 is OOS.	3.4
15	MAO-1 not scheduled	MAO-1 is not scheduled.	3.12

---

## 5.4 Troubleshooting the Link Master Function

### When the Scheduler Stops, the DX/MV Does Not Transit to Scheduler

**1. Check that the DX/MV is configured as an link master device.**

Check that the `BOOT_OPERAT_FUNCTIONAL_CLASS` (MIB, index number 367) value is set to 2 (Link Master, see section 3.13).

**2. Check that the node address of the DX/MV is smaller than other link master devices.**

This Node value of `DLME_BASIC_INFO` (MIB, index number 361) indicates the node address.

Reference section: 3.14

### Would Like to Transit the DX/MV to Scheduler while the Scheduler Is in Operation

**1. Check that the version number of the schedule in execution matches between the scheduler in operation and the DX/MV.**

On the DX/MV, the Active Schedule Version value of `LINK_SCHEDULE_LIST_CHARACTERISTICS_RECORD` (MIB, index number 374) is the schedule version number (see the explanation of `LINK_SCHEDULE_LIST_CHARACTERISTICS_RECORD` in appendix 2).

**2. Declare the DX/MV to become the scheduler**

First, set the `PRIMARY_LINK_MASTER_FLAG_VARIABLE` parameter of the scheduler in operation to 0x00 (false).

Then, set `PRIMARY_LINK_MASTER_FLAG_VARIABLE` (MIB, index number 364) of the DX/MV to 0xff (true).

See the explanation of `PRIMARY_LINK_MASTER_FLAG_VARIABLE` in appendix 4.

### Other Devices Cannot Be Connected to the Fieldbus on Which the DX/MV is Operating as the Scheduler

**1. Check that the following parameter value of the DX/MV is greater than the parameter value of the device to be connected.**

DX/MV		Device to Be Connected
V(ST)	>	V(ST)
V(MID)	>	V(MID)
V(MRD)	>	V(MRD)

- **DX/MV parameter**

The Slot Time value (subindex number 1) of `CONFIGURED_LINK_SETTING_RECORD` (MIB, index number 369) is V(ST). The Min Inter Pdu Delay value is V(MID). The MAX Response Delay value is V(MRD).

- **Parameter of the device to be connected**

The Slot Time value of `DLME_BASIC_INFO` is V(ST). The Min Inter Pdu Delay value is V(MID). The MAX Response Delay value is V(MRD).

**2. Check that the node address of the device to be connected is included in the node address range to be used specified by the DX/MV.**

For the procedure in setting the node address range to be used, see section 3.14.

# Appendix 1 Terminology

## Basic Device

Basic device is a field device that does not have scheduler functionality. There can be multiple basic devices on a single fieldbus.

## Communication Types (Client/Server)

The device that wishes to communicate (client) transmits a message to the destination device (server) when it receives permission from the scheduler. The server does not respond immediately; it responds when it receives permission from the scheduler.

- This type of communication is used for unscheduled communications such as the downloading of all the parameters of a device.
- It is one to one communication.
- The messages are transmitted or received in order without a loss or overwriting.

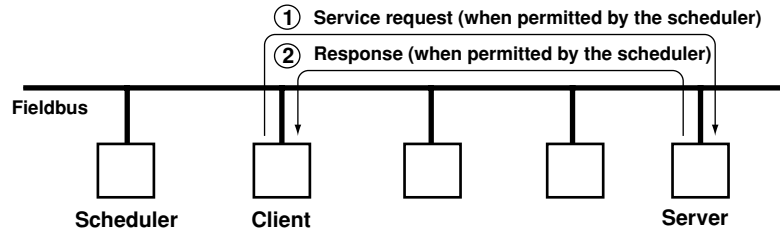

## Communication Types (Publisher/Subscriber)

The device (publisher) that receives a transmit request from the scheduler broadcasts the data to all devices on the fieldbus. Devices that are set to receive the data (subscriber) saves the data.

- This type of communication is used for scheduled, cyclic data transfers.
- It is one to many communications.
- A scheduler issues the data transfer request.
- The subscriber saves only the latest version of the data. New data overwrites previous data.

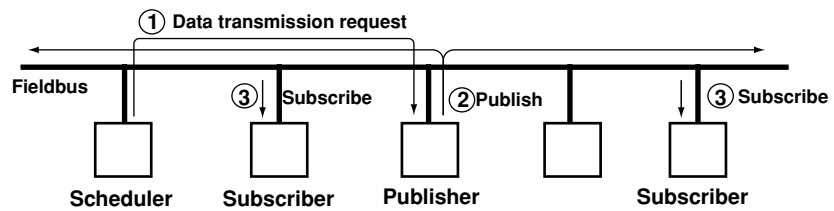



**Communication Types (Report distribution)**

The device that wishes to distribute a message transmits the message to the specified addresses when it receives permission from the scheduler. The receiving devices receive the message.

- This type of communication is used for unscheduled communications such as the transmission of alarms.
- It is one to many communications.
- The messages are transmitted or received in order without overwriting.

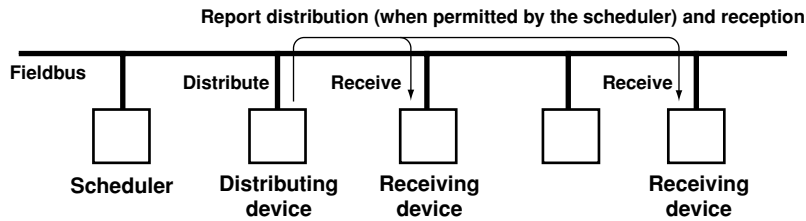

**Link Master Device (LM device)**

Link master device has functions that control the fieldbus communications. There can be multiple link master devices on a single fieldbus. One of them controls the fieldbus communications as a scheduler. If the preexisting scheduler malfunctions, one of other link master devices will become a scheduler.

**Object Dictionary (OD)**

The fieldbus function is expressed using a framework called objects. The function blocks are expressed as a group of objects.

Objects are stored in a list called an object dictionary (OD). The object dictionary is referenced externally by a logical device called a virtual field device (VFD).

**Scheduler (LAS, Link Active Scheduler)**

Controls the fieldbus communications. One of the link master devices on the fieldbus become a scheduler.

**Schedule**

Operations are scheduled and repeated at specified cycles (control cycles).

The following figure shows an example of schedule for a control loop with a transmitter and a controller + actuator.

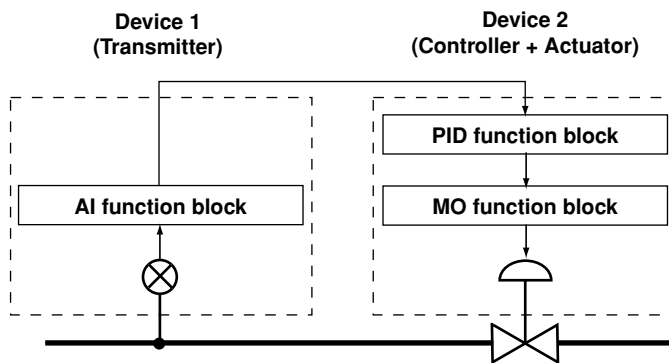

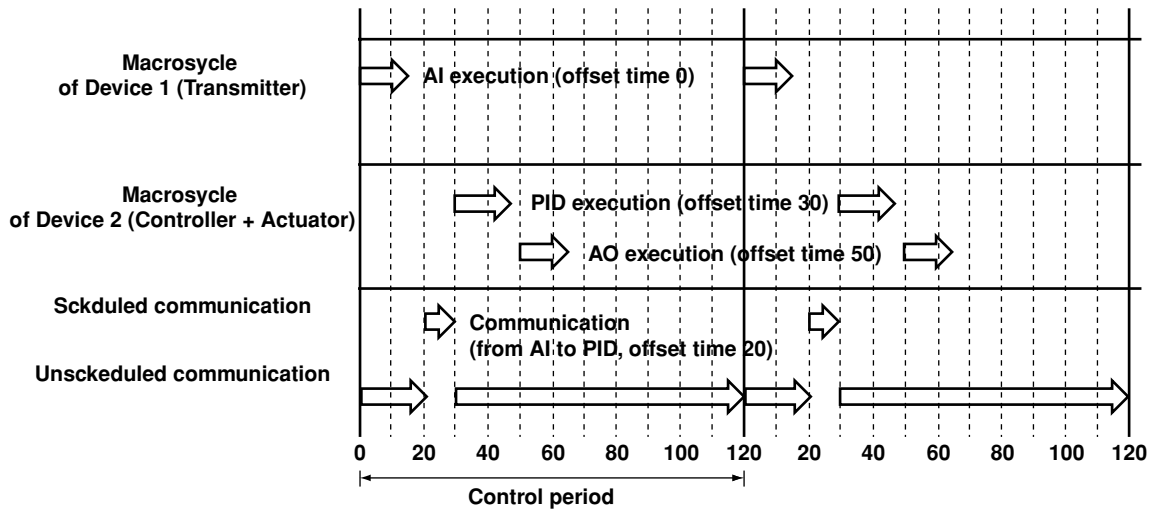

At offset 0, device 1 (transmitter) executes the analog input (AI) function block and prepares the measured data.

At offset 20, the scheduler issues a request to device 1 for transferring the measured data. The measured data is transmitted from device 1 to the fieldbus. The measured data is received by device 2.

At offset 30, device 2 (controller and actuator) executes the PID control function block and prepares the output data.

At offset 50, device 2 executes the analog output (AO) function block to read the output data of the PID function block and adjusts the valve. In this case, the data is exchanged within the same device. Thus, communication is not used.

### Scheduled Communications

Communication for data transmission for control loops or monitor loops are scheduled. The scheduler has a schedule list that determines transmission times for all buffers of all devices that need data transmission, and issues transmission requests to publishers based on the list.

The publisher broadcasts the data in the specified buffer to the fieldbus, when it receives the request.

Subscribers on the fieldbus stores the published data accordingly.

### Transition to Scheduler

If there is no scheduler on the fieldbus such as when starting up a fieldbus or a preexisting scheduler malfunctions, a link master device declares that it will become a scheduler and makes the transition.

If there are multiple link master devices on the fieldbus, the link master device with a smallest value of the node address can become a scheduler.

When a time period of  $V(ST) \times V(TN)$  elapses after the fieldbus has become silent, the link master device requests for an assignment of the scheduler rights.  $V(ST)$  and  $V(TN)$  are Slot Time (CURRENT\_LINK\_SETTING\_RECORD) and node address value, respectively.

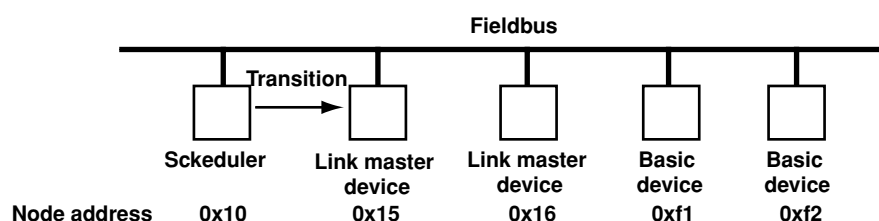

### **Unscheduled Communications**

Communications that transmit device alarms and configure devices are unscheduled communications. Unscheduled communications can occur during the time when scheduled communications are not being performed. The scheduler gives permission for communication to the devices on the fieldbus in order and repeatedly.

Devices are allowed to communicate till the message transmission ends or for the predetermined time period, either one which is shorter.

### **Virtual Communication Relationship (VCR)**

The virtual communication relationship is a logical communication pass to exchange messages. Communication with other devices is carried out based on the method determined by the VCR. Once it is configured, communication with other devices can be carried out simply by specifying the virtual communication relationship number.

The virtual communication relationships include three types that correspond to the communication types (Publisher/Subscriber, Report Distribution, Client/Server).

### **Virtual Field Device (VFD)**

A virtual field device is a logical device used to externally reference data described in Object Dictionary. There are two types of VFD, a management VFD, and a function block VFD.

You can access to VCR, communication, or schedule parameters through the system and network management VFD. While the parameters in the resource block, transducer block, and function blocks can be accessed through the function block VFD.

# Appendix 2 Parameters

## Management Information Base Virtual Field Device Parameters

The entire list of parameters in Management Information Base Virtual Field Device (MIB-VFD) is given below. For the functions of parameters, see the specifications issued by the Fieldbus Foundation.

### How to Read the Management Information Base Virtual Field Device Table

Index No.	Parameter name	See below.	--: Read only, W: Can be written	Value at delivery
Index	Parameter	Data Type	Attribute	Initial Value

### Data Type

Type	Size (byte)	Description
Domain	-	Domain
Boolean	1	true or false
Sign8	1	8-bit signed integer
Sign16	2	16-bit signed integer
Sign32	4	32-bit signed integer
Usign8	1	8-bit unsigned integer
Usign16	2	16-bit unsigned integer
Usign32	4	32-bit unsigned integer
Float	4	Floating-point data
Visible[ ]	1, 2, ..	Character string. Enclosed in parentheses are number of bytes.
Octet[ ]	1, 2, ..	Hexadecimal. Enclosed in parentheses are number of bytes.
Date	7	Date
Day	4 or 6	Time
Time Diff	4 or 6	Time difference
Bit[ ]	1, 2, ..	Bit sequence. Enclosed in parentheses are number of bytes.
Time	8	Time
Array	-	Array
DS-xx	xx	Records. Enclosed in parentheses are number of bytes.

## Appendix 2 Parameters

Index	Parameter	Data Type	Attribute	Initial Value
258	SM_SUPPORT	Bit[4]	-	0x00003c1f
259	T1	Usign32	W	480000
260	T2	Usign32	W	2880000
261	T3	Usign32	W	1440000
262	CURRENT_TIME	Time	-	0
263	LOCAL_TIME_DIFF	Sign32	W	60
264	AP_CLOCK_SYNC_INTERVAL	Usign8	W	60
265	TIME_LAST_RCVD	Time	-	0
266	PRIMARY_AP_TIME_PUBLISHER	Usign8	W	0
267	TIME_PUBLISHER_ADDR	Usign8	-	0
269	MACRO_CYCLE_DURATION	Usign32	W	32000
270	DEV_ID	Visible[32]	-	5945431801 ..
271	PD_TAG	Visible[32]	-	DAQSTATION
272	OPERATIONAL_POWERUP	Boolean	W	true
273	VFD_REF_ENTRY.1	DS-90		
	1 Vfd Ref	Usign32	-	1
	2 Vfd Tag	Visible[32]	W	MIB-VFD
274	VFD_REF_ENTRY.2	DS-90		
	1 Vfd Ref	Usign32	-	4660
	2 Vfd Tag	Visible[32]	W	FB-VFD
275	VERSION_OF_SCHEDULE	Usign16	W	1
276	FB_START_ENTRY.1	DS-91		
	1 Start Time Offset	Usign32	W	0
	2 Fb Object Index	Usign16	W	4000
	3 Vfd Ref	Usign32	-	4660
277	FB_START_ENTRY.2	DS-91		
	1 Start Time Offset	Usign32	W	960
	2 Fb Object Index	Usign16	W	4100
	3 Vfd Ref	Usign32	-	4660
278	FB_START_ENTRY.3	DS-91		
	1 Start Time Offset	Usign32	W	1920
	2 Fb Object Index	Usign16	W	4200
	3 Vfd Ref	Usign32	-	4660
279	FB_START_ENTRY.4	DS-91		
	1 Start Time Offset	Usign32	W	2880
	2 Fb Object Index	Usign16	W	4300
	3 Vfd Ref	Usign32	-	4660
280	FB_START_ENTRY.5	DS-91		
	1 Start Time Offset	Usign32	W	3840
	2 Fb Object Index	Usign16	W	4400
	3 Vfd Ref	Usign32	-	4660
281	FB_START_ENTRY.6	DS-91		
	1 Start Time Offset	Usign32	W	4800
	2 Fb Object Index	Usign16	W	4500
	3 Vfd Ref	Usign32	-	4660
282	FB_START_ENTRY.7	DS-91		
	1 Start Time Offset	Usign32	W	5760
	2 Fb Object Index	Usign16	W	4600
	3 Vfd Ref	Usign32	-	4660

Index	Parameter	Data Type	Attribute	Initial Value
283	FB_START_ENTRY.8	DS-91		
	1 Start Time Offset	Usign32	W	6720
	2 Fb Object Index	Usign16	W	4700
	3 Vfd Ref	Usign32	-	4660
284	FB_START_ENTRY.9	DS-91		
	1 Start Time Offset	Usign32	W	7680
	2 Fb Object Index	Usign16	W	9000
	3 Vfd Ref	Usign32	-	4660
285	FB_START_ENTRY.10	DS-91		
	1 Start Time Offset	Usign32	W	8640
	2 Fb Object Index	Usign16	W	10000
	3 Vfd Ref	Usign32	-	4660

Index	Parameter	Data Type	Attribute	Initial Value
290	STACK_CAPABILITIES	DS-95		
	1 Fas Ar Type and Role Supported	Octet[4]	-	0x40860000
	2 Max Dlsap Addresses Supported	Usign16	-	32
	3 Max Dlcep Addresses Supported	Usign16	-	31
	4 Dlcep Delivery Features Supported	Octet[1]	-	0xbb
	5 Version of Nm Spec Supported	Usign16	-	260
	6 Agent Functions Supported	Octet[1]	-	0x07
	7 Fms Features Supported	Bit[8]	-	0x1610c0100090000
291	VCR_LIST_CONTROL	Usign8	W	0
292	VCR_LIST_CHARACTERISTICS	DS-96		
	1 Version	Usign32	-	0
	2 Max Entries	Usign16	-	31
	3 Num Permanent Entries	Usign16	-	1
	4 Num Currently Configured	Usign16	-	15
	5 First Unconfigured Entry	Usign16	-	308
	6 Dynamics Supported Flag	Boolean	-	true
	7 Statistics Supported	Octet[1]	-	0x00
	8 Num of Statistics Entries	Usign16	-	0
293	VCR_STATIC_ENTRY.1	DS-97		
	1 Fas Ar Type and Role	Octet[1]	-	0x32
	2 Fas Dll Local Addr	Usign32	-	248
	3 Fas Dll Configured Remote Addr	Usign32	-	0
	4 Fas Dll SDAP	Octet[1]	-	0x2b
	5 Fas Dll Max Confirm Delay on Connect	Usign16	-	60000
	6 Fas Dll Max Confirm Delay on Data	Usign16	-	60000
	7 Fas Dll Max Dlsdu Size	Usign16	-	128
	8 Fas Dll Residual Activity Supported	Boolean	-	true
	9 Fas Dll Timeliness Class	Octet[1]	-	0x00
	10 Fas Dll Publisher Time Window Size	Usign16	-	0
	11 Fas Dll Publisher Synchronizing Dlcep	Usign32	-	0
	12 Fas Dll Subscriber Time Window Size	Usign16	-	0
	13 Fas Dll Subscriber Synchronizing Dlcep	Usign32	-	0
	14 Fms Vfd Id	Usign32	-	1

## Appendix 2 Parameters

Index	Parameter	Data Type	Attribute	Initial Value
	15 Fms Max Outstanding Services Calling	Usign8	-	0
	16 Fms Max Outstanding Services Called	Usign8	-	1
	17 Fms Features Supported	Bit[8]	-	0x1000c0100000000
294	VCR_STATIC_ENTRY.2	DS-97		
	1 Fas Ar Type and Role	Octet[1]	W	-
	2 Fas DII Local Addr	Usign32	W	-
	3 Fas DII Configured Remote Addr	Usign32	W	-
	4 Fas DII SDAP	Octet[1]	W	-
	5 Fas DII Max Confirm Delay on Connect	Usign16	-	-
	6 Fas DII Max Confirm Delay on Data	Usign16	-	-
	7 Fas DII Max DlSdu Size	Usign16	-	-
	8 Fas DII Residual Activity Supported	Boolean	-	-
	9 Fas DII Timeliness Class	Octet[1]	-	-
	10 Fas DII Publisher Time Window Size	Usign16	-	-
	11 Fas DII Publisher Synchronizing Dlcep	Usign32	-	-
	12 Fas DII Subscriber Time Window Size	Usign16	-	-
	13 Fas DII Subscriber Synchronizing Dlcep	Usign32	-	-
	14 Fms Vfd Id	Usign32	W	-
	15 Fms Max Outstanding Services Calling	Usign8	W	-
	16 Fms Max Outstanding Services Called	Usign8	W	-
	17 Fms Features Supported	Bit[8]	W	-
295	VCR_STATIC_ENTRY.3	DS-97		
:	:			
323	VCR_STATIC_ENTRY.31	DS-97		
324	VCR_DYNAMIC_ENTRY.1	DS-98		
	1 Fms State	Usign8	-	1
	2 Fms Actual Max Outstanding Services Calling	Usign8	-	0
	3 Fms Actual Max Outstanding Services Called	Usign8	-	1
	4 Fms Outstanding Services Counter Calling	Usign8	-	0
	5 Fms Outstanding Services Counter Called	Usign8	-	1
	6 Fas State	Usign8	-	1
	7 Fas DII Actual Remote Address	Usign32	-	4128
	8 Fas DII Max Sending Queue Depth	Usign8	-	1
	9 Fas DII Max Receiving Queue Depth	Usign8	-	1
325	VCR_DYNAMIC_ENTRY.2	DS-98		
:	:			
358	VCR_DYNAMIC_ENTRY.31	DS-98		
360	DLME_BASIC_CHARACTERISTICS	DS-100		
	1 Version	Usign8	-	1
	2 Basic Statistics Supported Flag	Boolean	-	false
	3 DI Operat Functional Class	Usign8	-	2
	4 DI Device Conformance	Octet[4]	-	0x20210c84

Index	Parameter	Data Type	Attribute	Initial Value
361	DLME_BASIC_INFO	DS-101		
	1 Slot Time	Usign16	-	4
	2 Per Dlpdu Phl Overhead	Usign8	-	4
	3 Max Response Delay	Usign8	-	3
	4 This Node	Usign8	-	245
	5 This Link	Usign16	-	0
	6 Min Inter Pdu Delay	Usign8	-	4
	7 Time Sync Class	Usign8	-	4
	8 Preamble Extension	Usign8	-	2
	9 Post Trans Gap Extension	Usign8	-	1
	10 Max Inter Chan Signal Skew	Usign8	-	0
362	DLME_LINK_MASTER_CAPABILITIES_VARIABLE	Octet[1]	W	0x04
363	DLME_LINK_MASTER_INFO_RECORD	DS-104		
	1 Max Scheduling Overhead	Usign8	W	0
	2 Def Min Token Deleg Time	Usign16	W	100
	3 Def Token Hold Time	Usign16	W	300
	4 Target Token Rot Time	Usign16	W	4096
	5 Link Maint Tok Hold Time	Usign16	W	400
	6 Time Distribution Period	Usign32	W	5000
	7 Maximum Inactivity to Claim Las Delay	Usign16	W	2
	8 Las Database Status Spdu Distribution Period	Usign16	W	6000
364	PRIMARY_LINK_MASTER_FLAG_VARIABLE	Boolean	W	false
365	LIVE_LIST_STATUS_ARRAY_VARIABLE	Octet[32]	-	0x0
366	MAX_TOKEN_HOLD_TIME_ARRAY	Array		
	1 Element 1	Octet[64]	W	-
	2 Element 2	Octet[64]	W	-
	3 Element 3	Octet[64]	W	-
	4 Element 4	Octet[64]	W	-
	5 Element 5	Octet[64]	W	-
	6 Element 6	Octet[64]	W	-
	7 Element 7	Octet[64]	W	-
	8 Element 8	Octet[64]	W	-
367	BOOT_OPERAT_FUNCTIONAL_CLASS	Usign8	W	2
368	CURRENT_LINK_SETTING_RECORD	DS-111		
	1 Slot Time	Usign16	-	-
	2 Per Dlpdu Phl Overhead	Usign8	-	-
	3 Max Response Delay	Usign8	-	-
	4 First Unpolled Node Id	Usign8	-	-
	5 This Link	Usign16	-	-
	6 Min Inter Pdu Delay	Usign8	-	-
	7 Num Consec Unpolled Node Id	Usign8	-	-
	8 Preamble Extension	Usign8	-	-
	9 Post Trans Gap Extension	Usign8	-	-
	10 Max Inter Chan Signal Skew	Usign8	-	-
	11 Time Sync Class	Usign8	-	-
369	CONFIGURED_LINK_SETTING_RECORD	DS-111		
	1 Slot Time	Usign16	W	10
	2 Per Dlpdu Phl Overhead	Usign8	W	4
	3 Max Response Delay	Usign8	W	10



## Appendix 2 Parameters

Index	Parameter	Data Type	Attribute	Initial Value
	4 First Unpolled Node Id	Usign8	W	37
	5 This Link	Usign16	W	0
	6 Min Inter Pdu Delay	Usign8	W	16
	7 Num Consec Unpolled Node Id	Usign8	W	186
	8 Preamble Extension	Usign8	W	2
	9 Post Trans Gap Extension	Usign8	W	1
	10 Max Inter Chan Signal Skew	Usign8	W	0
	11 Time Sync Class	Usign8	W	4
370	PLME_BASIC_CHARACTERISTICS	DS-108		
	1 Channel Statistics Supported	Octet[1]	-	0
	2 Medium and Data Rates Supported	Octet[8]	-	49000000 00000000
	3 lec Version	Usign16	-	1
	4 Num of Channels	Usign8	-	1
	5 Power Mode	Usign8	-	0
371	CHANNEL_STATES_VARIABLE	Array		
	1 Channel 1	Usign8	-	0
	2 Channel 2	Usign8	-	128
	3 Channel 3	Usign8	-	128
	4 Channel 4	Usign8	-	128
	5 Channel 5	Usign8	-	128
	6 Channel 6	Usign8	-	128
	7 Channel 7	Usign8	-	128
	8 Channel 8	Usign8	-	128
372	PLME_BASIC_INFO	DS-109		
	1 Interface Mode	Usign8	-	0
	2 Loop Back Mode	Usign8	-	0
	3 Xmit Enabled	Usign8	-	1
	4 Rcv Enabled	Usign8	-	1
	5 Preferred Receive Channel	Usign8	-	1
	6 Media Type Selected	Usign8	-	73
	7 Receive Select	Usign8	-	1
373	LINK_SCHEDULE_ACTIVATION_VARIABLE	Usign16	W	0
374	LINK_SCHEDULE_LIST_CHARACTERISTICS_RECORD	DS-106		
	1 Num of Schedules	Usign8	-	1
	2 Num of Subschedules per Schedule	Usign8	-	1
	3 Active Schedule Version	Usign16	-	1
	4 Active Schedule Od Index	Usign16	-	377
	5 Active Schedule Starting Time	Time	-	0
375	DLME_SCHEDULE_DESCRIPTOR.1	DS-107		
	1 Version	Usign16	-	1
	2 Macrocycle Duration	Usign32	-	32000
	3 Time Resolution	Usign16	-	0
376	DLME_SCHEDULE_DESCRIPTOR.2	DS-107		
	1 Version	Usign16	-	0
	2 Macrocycle Duration	Usign32	-	0
	3 Time Resolution	Usign16	-	0
377	DOMAIN.1	Domain	-	-
378	DOMAIN.2	Domain	-	-

### Function Block Virtual Field Device Parameters

The entire list of parameters in Function Block Virtual Field Device (FB-VFD) is given below. For details on the parameter functions, see the specifications issued by the Fieldbus Foundation.

#### How to Read the Function Block Virtual Field Device Table

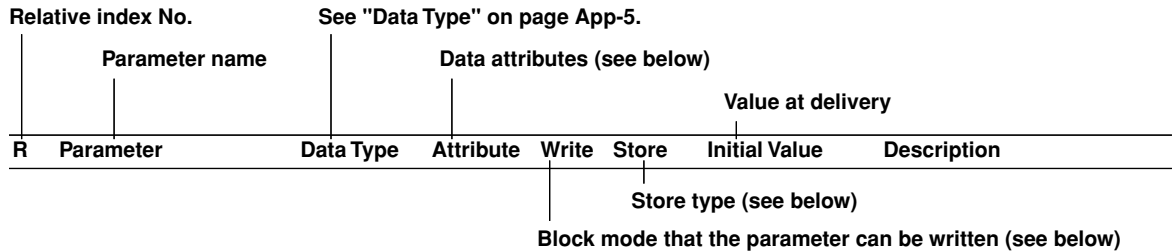

#### Data Attributes

Symbol	Description
I/*	Input parameter (subscribed by other function blocks)
O/*	Output parameter (published by the DX/MV)
C/*	Contained parameter (cannot be subscribed or published)
*/S	Static parameter (when a value is written, ST_REV value is increased by 1. Non-volatile.)
*/N	Non-volatile parameter
*/D	Dynamic parameter
*/M	Mixture of parameters with different attributes

#### Write Mode

Value	Description
-	Read only
OOS	Writable when the block mode is OOS
MAN	Writable when the block mode is MAN or OOS
ANY	Writable in all block modes

#### Storage Type

Value	Description
-	ROM data
RAM	Stored in RAM (erased when the power is turned OFF)
EEP	Stored in EEPROM (held even when the power is turned OFF)

## Appendix 2 Parameters

### Resource Block (First index number: 1000)

R	Parameter	Data Type	Attribute	Write	Store	Initial Value	Description
0	BLOCK	DS-64	C/S				Structure information of the block
1	Block Tag	Visible[32]	C/S	OOS	EEP	RB	Block tag (up to 32 characters). Must be unique within the segment.
2	DD Member ID	Usign32	C/S	-	-	0x0	DD search key
3	DD Item ID	Usign32	C/S	-	-	0x80020af0	DD search key
4	DD Revision	Usign16	C/S	-	-	1	DD revision
5	Profile	Usign16	C/S	-	-	0x010b	Block type, RB is "0x010b"
6	Profile Revision	Usign16	C/S	-	-	0x0101	Profile revision
7	Execution Time	Usign32	C/S	-	-	0	Execution time (0 for RB because it is self-run at all times)
8	Period of Execution	Usign32	C/S	ANY	-	0	Execution period (0 for RB because it is self-run at all times)
9	Number of Parameters	Usign16	C/S	-	-	53	Number of parameters making up the block
10	Next FB to Execute	Usign16	C/S	ANY	-	0	Not applicable to the RB
11	Starting Index of Views	Usign16	C/S	-	-	40100	Start index of VIEW_1
12	Number of VIEW_3	Usign8	C/S	-	-	1	Number of VIEW_3s
13	Number of VIEW_4	Usign8	C/S	-	-	1	Number of VIEW_4s
1	ST_REV	Usign16	C/S	-	EEP	0	Static parameter revision. The value increases every time a value is written to the static parameter.
2	TAG_DESC	Octet[32]	C/S	ANY	EEP	(all space)	User memo area
3	STRATEGY	Usign16	C/S	ANY	EEP	1	User memo area
4	ALERT_KEY	Usign8	C/S	ANY	EEP	1	Indicates the source of the alarm using a value between 1 and 255 (the user defines the relationship between the values and meanings). Copied to Alert Key of the alert object.
5	MODE_BLK	DS-69	C/M			-	Mode setting and indication
1	Target	Bit[1]	C/N	ANY	EEP	auto	Transition destination mode setting
2	Actual	Bit[1]	C/D	-	RAM	auto	Current mode
3	Permitted	Bit[1]	C/S	ANY	EEP	auto oos	Permitted modes for transition
4	Normal	Bit[1]	C/S	ANY	EEP	auto	Transition destination mode when resuming to normal operation.
6	BLOCK_ERR	Bit[2]	C/D	-	RAM	0	Block error state (section 5.2)
7	RS_STATE	Usign8	C/D	-	RAM	start	Resource block state (section 5.2)
8	TEST_RW	DS-85	C/D				Variable used to test the Read/Write to the parameter (Data can be written freely to Values 1 through 15)
1	Value 1	Boolean	C/D	ANY	RAM	0	
2	Value 2	Sign8	C/D	ANY	RAM	0	
3	Value 3	Sign16	C/D	ANY	RAM	0	
4	Value 4	Sign32	C/D	ANY	RAM	0	
5	Value 5	Usign8	C/D	ANY	RAM	0	
6	Value 6	Usign16	C/D	ANY	RAM	0	
7	Value 7	Usign32	C/D	ANY	RAM	0	
8	Value 8	Float	C/D	ANY	RAM	0	
9	Value 9	Visible[32]	C/D	ANY	RAM		
10	Value 10	Octet[32]	C/D	ANY	RAM	(null)	
11	Value 11	Date	C/D	ANY	RAM	uninitialized	
12	Value 12	Day	C/D	ANY	RAM	0	
13	Value 13	Time Diff	C/D	ANY	RAM	0	

R	Parameter	Data Type	Attribute	Write	Store	Initial Value	Description
	14 Value 14	Bit[2]	C/D	ANY	RAM	0	
	15 Value 15	Time	C/D	ANY	RAM	0	
9	DD_RESOURCE	Visible[32]	C/S	FM	EEP		Variable used by the configurator to determine the location of the DD
10	MANUFAC_ID	Usign32	C/S	-	-	0x594543	Manufacturer ID, Used when the configurator determines the location of the DD
11	DEV_TYPE	Usign16	C/S	FM	EEP	0x1801	Device type Used when the configurator determines the location of the DD
12	DEV_REV	Usign8	C/S	FM	EEP	3	Device revision number Used when the configurator determines the location of the DD
13	DD_REV	Usign8	C/S	FM	EEP	1	DD revision number Used when the configurator determines the location of the DD
14	GRANT_DENY	DS-70	C/D				Not used
	1 Grant	Bit[1]	C/D	ANY	RAM	0	Not used
	2 Deny	Bit[1]	C/D	ANY	RAM	0	Not used
15	HARD_TYPES	Bit[2]	C/S	-	-	input	Hardware type The DX/MV only supports Scalar Input (bit 0 is "1")
16	RESTART	Usign8	C/D	ANY	RAM	run	Variable indicating the block initialization level. 1: Run (do not initialize) 2: Restart resource (do not initialize) 3: Restart with defaults (Set the parameters to fieldbus foundation default) 4: restart processor (Restart the CPU)
17	FEATURES	Bit[2]	C/S	-	-	report soft_lock	Options that the RB supports DX/MV supports the following two items. Report (bit 1 is "1") soft write lock (bit 3 is "1")
18	FEATURE_SEL	Bit[2]	C/S	ANY	EEP	report soft_lock	Of those options that the RB supports (FEATURES), the one that is to be used
19	CYCLE_TYPE	Bit[2]	C/S	-	-	scheduled	Type of execution cycle that the DX/MV supports Scheduled (bit 0 is "1") only
20	CYCLE_SEL	Bit[2]	C/S	ANY	RAM	scheduled	Of those types of execution cycles (CYCLE_TYPE) that the DX/MV supports, the one that is to be used
21	MIN_CYCLE_T	Usign32	C/S	-	-	3200	Minimum value of execution cycle that the RB can permit (the unit is 1/32 ms) Since the RB of the DX/MV is self-run, the value does not affect the process (the initial value is a provisional value)
22	MEMORY_SIZE	Usign16	C/S	-	-	0	Size of memory that can be used in the configuration Memory area is not available on the DX/MV (the value is 0)

## Appendix 2 Parameters

R	Parameter	Data Type	Attribute	Write	Store	Initial Value	Description
23	NV_CYCLE_T	Usign32	C/S	-	-	0	Cycle at which the non-volatile parameters of the FB are to be automatically written to the non-volatile memory (the unit is 1/32 ms). On the DX/MV, values are written only when the operation is carried out (values are not written automatically, the value is 0)
24	FREE_SPACE	Float	C/D	-	-	0	Size of free memory that can be used in the configuration Memory area is not available on the DX/MV (the value is 0)
25	FREE_TIME	Float	C/D	-	-	0	Free time that can be used in the additional processing of the block There is no time that can be used in the additional processing on the DX/MV (the value is 0)
26	SHED_RCAS	Usign32	C/S	ANY	EEP	640000	Time from the point when the status of the remote control input from the upper system has gone bad to the point when the mode transition is made (the unit is 1/32 ms) Not used on the DX/MV (the initial value is a provisional value)
27	SHED_ROUT	Usign32	C/S	ANY	EEP	640000	Time from the point when the status of the remote control input from the upper system has gone bad to the point when the mode transition is made (the unit is 1/32 ms) Not used on the DX/MV (the initial value is a provisional value)
28	FAULT_STATE	Usign8	C/N	-	EEP	clear	Variable that determines the operation of the block when the communication is cut 1: Clear (not Fault State condition) 2: active (Fault State condition) Can be specified using SET_FSTATE or CLR_FSTATE
29	SET_FSTATE	Usign8	C/D	ANY	RAM	off	Variable used to set the DX/MV to Fault State condition (see CLR_FSTATE) 1: Off 2: Set (Set to Fault State condition. Return to Off after Fault State condition.)
30	CLR_FSTATE	Usign8	C/D	ANY	RAM	off	Variable used to release the Fault State condition of the DX/MV (see SET_FSTATE) 1: Off 2: Set (Release the condition. Return to Off after releasing the Fault State condition.)
31	MAX_NOTIFY	Usign8	C/S	-	-	3	Maximum number of alerts that can be transmitted simultaneously Fixed to 3 on the DX/MV
32	LIM_NOTIFY	Usign8	C/S	ANY	EEP	3	Number of alerts that can be transmitted simultaneously Value less than or equal to MAX_NOTIFY can be specified. When set to "0," alert is not transmitted.

R	Parameter	Data Type	Attribute	Write	Store	Initial Value	Description
33	CONFIRM_TIME	Usign32	C/S	ANY	EEP	640000	Time until the alert is retransmitted when there is no acknowledge in response to the alert transmission (the unit is 1/32 ms) If you specify 0, alert retransmission is disabled.
34	WRITE_LOCK	Usign8	C/S	ANY	EEP	unlock	Variable used to control the writing to the FB parameter 1: Unlocked (writable) 2: Locked (not writable)
35	UPDATE_EVT	DS-73	C/D				Update event state
	1 Unacknowledged	Usign8	C/D	ANY	RAM	ack	Response to the event transmission 1: Acknowledged (acknowledged, specifiable) 2: Unacknowledged (no acknowledge)
	2 Update State	Usign8	C/D	-	RAM	report	Event transmission 1: Reported (transmitted) 2: Not reported (not transmitted)
	3 Time Stamp	Time	C/D	-	RAM	0	Time when the update was executed
	4 Static Revision	Usign16	C/D	-	RAM	0	ST_REV value during the update execution
	5 Relative Index	Usign16	C/D	-	RAM	0	Relative index number of the updated parameter The value is set to "0" when multiple parameters are updated simultaneously.
36	BLOCK_ALM	DS-72	C/D				Block alarm status
	1 Unacknowledged	Usign8	C/D	ANY	RAM	ack	Response to the alert transmission 1: Acknowledged (acknowledged, specifiable) 2: Unacknowledged (no acknowledge)
	2 Alarm State	Usign8	C/D	-	RAM	report	Alert transmission 1: Reported (transmitted) 2: Not reported (not transmitted)
	3 Time Stamp	Time	C/D	-	RAM	0	Time when the alarm occurred
	4 Subcode	Usign16	C/D	-	RAM	0	BLOCK_ERR value when the alarm occurred
	5 Value	Usign8	C/D	-	RAM	0	Not used
37	ALARM_SUM	DS-74	C/M				Alarm summary of the RB
	1 Current	Bit[2]	C/D	-	RAM	0	Alarm that is currently in effect (indicated using Bits) Bit 0: Write lock alarm Bit 1: HI_HI alarm Bit 2: HI alarm Bit 3: LO_LO alarm Bit 4: LO alarm Bit 7: Block alarm
	2 Unacknowledged	Bit[2]	C/D	-	RAM	0	Alert not acknowledged by the host (the correspondence between the bits and alarms is the same as Current)
	3 Unreported	Bit[2]	C/D	-	RAM	0	Untransmitted alert (the correspondence between the bits and alarms is the same as Current)
	4 Disabled	Bit[2]	C/S	ANY	EEP	0xffff	Variable used to set whether to activate the alarm (the correspondence between the bits and alarms is the same as Current)

## Appendix 2 Parameters

R	Parameter	Data Type	Attribute	Write	Store	Initial Value	Description
38	ACK_OPTION	Bit[2]	C/S	ANY	EEP	0x81	Variable used to set the auto acknowledge of alarms (specify the alarms to auto acknowledge using bits. The correspondence between the bits and alarms is the same as Current of ALARM_SUM)
39	WRITE_PRI	Usign8	C/S	ANY	EEP	0	Priority of the WRITE_LOCK alarm Value: 0, 1, 3 through 15
40	WRITE_ALM	DS-72	C/D				State of the WRITE_LOCK alert
	1 Unacknowledged	Usign8	C/D	ANY	RAM	ack	Response to the alert transmission 1: Acknowledged (acknowledged, specifiable) 2: Unacknowledged (no acknowledge)
	2 Alarm State	Usign8	C/D	-	RAM	report	Alert state 1: Clear-reported (clear write lock, transmitted) 2: Clear-not reported (clear write lock, not transmitted) 3: Active-reported (write lock transmitted) 4: Active-not reported (write lock not transmitted)
	3 Time Stamp	Time	C/D	-	RAM	0	Time when the alarm occurred
	4 Subcode	Usign16	C/D	-	RAM	0	Not used.
	5 Value	Usign8	C/D	-	RAM	0	WRITE_LOCK value when the alarm occurred
	41 ITK_VER	Usign16	C/S	-	-	4	Version of the interoperability test (ITK) that the DX/MV conducted
42	SOFT_REV	Visible[32]	C/N	-	-	R1.01	Software revision
43	SOFT_DESC	Visible[32]	C/N	-----For Manufacturer's use only. Do not operate this parameter.-----			
44	SIM_ENABLE_MSG	Visible[32]	C/N	ANY	-		Variable used to turn On/Off the Simulation Jumper The Simulation Jumper is turned ON when "REMOTE LOOP TEST SWITCH" is written (Off otherwise. Off when the power is turned Off)
45	DEVICE_STATUS_1	Bit[4]	C/D	-	RAM	0	Variable that indicates the status of the RB and VCR (section 5.3)
46	DEVICE_STATUS_2	Bit[4]	C/D	-	RAM	0	Variable that indicates the status of the TB and identification information (section 5.3)
47	DEVICE_STATUS_3	Bit[4]	C/D	-	RAM	0	Variable that indicates the status of AI-1 through AI-8 (section 5.3)
48	DEVICE_STATUS_4	Bit[4]	C/D	-	RAM	0	Variable that indicates the status of the MAI (section 5.3)
49	DEVICE_STATUS_5	Bit[4]	C/D	-	RAM	0	Variable that indicates the status of the MAO (section 5.3)
50	DEVICE_STATUS_6	Bit[4]	C/D	-	RAM	0	Not used
51	DEVICE_STATUS_7	Bit[4]	C/D	-	RAM	0	Not used
52	DEVICE_STATUS_8	Bit[4]	C/D	-	RAM	0	Not used

## Transducer Block (First index number: 2000)

R	Parameter	Data Type	Attribute	Write	Store	Initial Value	Description
0	BLOCK	DS-64	C/S				Structure information of the block
1	Block Tag	Visible[32]	C/S	OOS	EEP	TB	Block tag (up to 32 characters). Must be unique within the segment.
2	DD Member ID	Usign32	C/S	-	-	0x0	DD search key
3	DD Item ID	Usign32	C/S	-	-	0x20010	DD search key
4	DD Revision	Usign16	C/S	-	-	1	DD revision
5	Profile	Usign16	C/S	-	-	0x9801	Block type, TB is "0x9801"
6	Profile Revision	Usign16	C/S	-	-	0x0001	Profile revision
7	Execution Time	Usign32	C/S	-	-	0	Execution time (0 for TB because it is self-run at all times)
8	Period of Execution	Usign32	C/S	ANY	EEP	0	Execution period (0 for TB because it is self-run at all times)
9	Number of Parameters	Usign16	C/S	-	-	25	Number of parameters making up the block
10	Next FB to Execute	Usign16	C/S	ANY	EEP	0	Not applicable to the TB
11	Starting Index of Views	Usign16	C/S	-	-	40200	Start index of VIEW_1
12	Number of VIEW_3	Usign8	C/S	-	-	1	Number of VIEW_3s
13	Number of VIEW_4	Usign8	C/S	-	-	1	Number of VIEW_4s
1	ST_REV	Usign16	C/S	-	EEP	0	Static parameter revision. The value increases every time a value is written to the static parameter.
2	TAG_DESC	Octet[32]	C/S	ANY	EEP	(all space)	User memo area
3	STRATEGY	Usign16	C/S	ANY	EEP	1	User memo area
4	ALERT_KEY	Usign8	C/S	ANY	EEP	1	See the explanation of the RB parameter.
5	MODE_BLK	DS-69	C/M				Mode setting and indication
1	Target	Bit[1]	C/N	ANY	EEP	auto	Transition destination mode setting
2	Actual	Bit[1]	C/D	-	RAM	auto	Current mode
3	Permitted	Bit[1]	C/S	ANY	EEP	auto oos	Permitted modes for transition
4	Normal	Bit[1]	C/S	ANY	EEP	auto	Transition destination mode when resuming to normal operation.
6	BLOCK_ERR	Bit[2]	C/D	-	RAM	0	Block error state (section 5.2)
7	UPDATE_EVT	DS-73	C/D				Update event state
1	Unacknowledged	Usign8	C/D	ANY	RAM	ack	See the explanation of the RB parameter.
2	Update State	Usign8	C/D	-	RAM	report	See the explanation of the RB parameter.
3	Time Stamp	Time	C/D	-	RAM	0	See the explanation of the RB parameter.
4	Static Revision	Usign16	C/D	-	RAM	0	See the explanation of the RB parameter.
5	Relative Index	Usign16	C/D	-	RAM	0	See the explanation of the RB parameter.
8	BLOCK_ALM	DS-72	C/D				Block alarm status
1	Unacknowledged	Usign8	C/D	ANY	RAM	ack	See the explanation of the RB parameter.
2	Alarm State	Usign8	C/D	-	RAM	report	See the explanation of the RB parameter.
3	Time Stamp	Time	C/D	-	RAM	0	See the explanation of the RB parameter.
4	Subcode	Usign16	C/D	-	RAM	0	See the explanation of the RB parameter.
5	Value	Usign8	C/D	-	RAM	0	See the explanation of the RB parameter.
9	TRANSDUCER_DIREC..	Array[1]	C/N				Information of the "Transducer" of the TB
1	Number of Transduc..	Usign16	C/N	-	-	0	The number of "Transducers." The DX/MV has a single Transducer.
10	TRANSDUCER_TYPE	Usign16	C/N	-	-	other	"Transducer" type.
11	XD_ERROR	Usign8	C/D	-	RAM	0	"Transducer" error state.



## Appendix 2 Parameters

R	Parameter	Data Type	Attribute	Write	Store	Initial Value	Description
12	COLLECTION_DIRECT..	Array[1]	C/N				Information of the "Transducer" of the TB
1	Number of Collections	Usign32	C/N	-	-	0	The number of "Collections." The DX/MV has a single Collection.
13	AI_MAP	Array[8]	C/S				Mapping between the measurement and computation channels of the DX/MV and the AI channels
1	CHANNEL - 1	Usign16	C/S	OOS	EEP	1	Measurement or computation channel number to be connected
2	CHANNEL - 2	Usign16	C/S	OOS	EEP	2	Measurement or computation channel number to be connected
3	CHANNEL - 3	Usign16	C/S	OOS	EEP	3	Measurement or computation channel number to be connected
4	CHANNEL - 4	Usign16	C/S	OOS	EEP	4	Measurement or computation channel number to be connected
5	CHANNEL - 5	Usign16	C/S	OOS	EEP	5	Measurement or computation channel number to be connected
6	CHANNEL - 6	Usign16	C/S	OOS	EEP	6	Measurement or computation channel number to be connected
7	CHANNEL - 7	Usign16	C/S	OOS	EEP	7	Measurement or computation channel number to be connected
8	CHANNEL - 8	Usign16	C/S	OOS	EEP	8	Measurement or computation channel number to be connected
14	MAI_MAP	Array[8]	C/S				Mapping between the measurement and computation channels of the DX/MV and the OUT_1 through OUT_8 of the MAI.
1	OUT_1	Usign16	C/S	OOS	EEP	1	Measurement or computation channel number to be connected
2	OUT_2	Usign16	C/S	OOS	EEP	2	Measurement or computation channel number to be connected
3	OUT_3	Usign16	C/S	OOS	EEP	3	Measurement or computation channel number to be connected
4	OUT_4	Usign16	C/S	OOS	EEP	4	Measurement or computation channel number to be connected
5	OUT_5	Usign16	C/S	OOS	EEP	5	Measurement or computation channel number to be connected
6	OUT_6	Usign16	C/S	OOS	EEP	6	Measurement or computation channel number to be connected
7	OUT_7	Usign16	C/S	OOS	EEP	7	Measurement or computation channel number to be connected
8	OUT_8	Usign16	C/S	OOS	EEP	8	Measurement or computation channel number to be connected
15	MAO_MAP	Array[8]	C/S				Mapping between the communication input channels of the DX/MV and IN_1 through IN_8 of the MAO
1	IN_1	Usign16	C/S	OOS	EEP	0	Communication input channel number to be connected
2	IN_2	Usign16	C/S	OOS	EEP	0	Communication input channel number to be connected
3	IN_3	Usign16	C/S	OOS	EEP	0	Communication input channel number to be connected
4	IN_4	Usign16	C/S	OOS	EEP	0	Communication input channel number to be connected
5	IN_5	Usign16	C/S	OOS	EEP	0	Communication input channel number to be connected

R	Parameter	Data Type	Attribute	Write	Store	Initial Value	Description
6	IN_6	Usign16	C/S	OOS	EEP	0	Communication input channel number to be connected
7	IN_7	Usign16	C/S	OOS	EEP	0	Communication input channel number to be connected
8	IN_8	Usign16	C/S	OOS	EEP	0	Communication input channel number to be connected
16	ALARM_SUM	DS-74	C/M				Displays the alarm summary of the TB
1	Current	Bit[2]	C/D	-	RAM	0	See the explanation of the RB parameter.
2	Unacknowledged	Bit[2]	C/D	-	RAM	0	See the explanation of the RB parameter.
3	Unreported	Bit[2]	C/D	-	RAM	0	See the explanation of the RB parameter.
4	Disabled	Bit[2]	C/S	ANY	EEP	0xffff	See the explanation of the RB parameter.
17	DEV_ID	Visible[32]	C/D	-----For Manufacturer's use only. Do not operate this parameter.-----			
18	DEV_KEY	Usign16	C/D	-----For Manufacturer's use only. Do not operate this parameter.-----			
19	EEPROM_STATE	Octet[32]	C/D	-----For Manufacturer's use only. Do not operate this parameter.-----			
20	UART_STATISTICS	Array[5]	C/D	-----For Manufacturer's use only. Do not operate this parameter.-----			
21	STACK_STATISTICS_1	Array[17]	C/D	-----For Manufacturer's use only. Do not operate this parameter.-----			
22	STACK_STATISTICS_2	Array[2]	C/D	-----For Manufacturer's use only. Do not operate this parameter.-----			
23	STACK_CONF	Usign16	C/D	-----For Manufacturer's use only. Do not operate this parameter.-----			
24	EXEC_FB_CNT	Array[11]	C/D	-----For Manufacturer's use only. Do not operate this parameter.-----			

## Appendix 2 Parameters

### AI Function Block

(First index numbers: 4000, 4100, 4200, 4300, 4400, 4500, 4600, 4700)

R	Parameter	Data Type	Attribute	Write	Store	Initial Value	Description
0	BLOCK	DS-64	C/S				Structure information of the block
	1 Block Tag	Visible[32]	C/S	OOS	EEP	AI-1 <sup>*1</sup>	Block tag (up to 32 characters). Must be unique within the segment.
	2 DD Member ID	Usign32	C/S	-	-	0x0	DD search key
	3 DD Item ID	Usign32	C/S	-	-	0x800201d0	DD search key
	4 DD Revision	Usign16	C/S	-	-	1	DD revision
	5 Profile	Usign16	C/S	-	-	0x0101	Block type MAI is "0x0101."
	6 Profile Revision	Usign16	C/S	-	-	0x0001	Profile revision
	7 Execution Time	Usign32	C/S	-	-	960	Execution time (the unit is 1/32 ms, read only)
	8 Period of Execution	Usign32	C/S	ANY	EEP	32000	Execution period (the unit is 1/32 ms, read only)
	9 Number of Parameters	Usign16	C/S	-	-	37	Number of parameters making up the block
	10 Next FB to Execute	Usign16	C/S	ANY	EEP	0	The FB to be executed next.
	11 Starting Index of Views	Usign16	C/S	-	-	40400 <sup>*2</sup>	Start index of VIEW_1
	12 Number of VIEW_3	Usign8	C/S	-	-	1	Number of VIEW_3s
	13 Number of VIEW_4	Usign8	C/S	-	-	1	Number of VIEW_4s
1	ST_REV	Usign16	C/S	-	EEP	0	Static parameter revision. The value increases every time a value is written to the static parameter.
2	TAG_DESC	Octet[32]	C/S	ANY	EEP	(all space)	User memo area
3	STRATEGY	Usign16	C/S	ANY	EEP	1	User memo area
4	ALERT_KEY	Usign8	C/S	ANY	EEP	1	See the explanation of the RB parameter.
5	MODE_BLK	DS-69	C/M				Mode setting and indication
	1 Target	Bit[1]	C/N	ANY	EEP	oos	Transition destination mode setting
	2 Actual	Bit[1]	C/D	-	RAM	oos	Current mode
	3 Permitted	Bit[1]	C/S	ANY	EEP	auto man oos	Permitted modes for transition
	4 Normal	Bit[1]	C/S	ANY	EEP	auto	Transition destination mode when resuming to normal operation.
6	BLOCK_ERR	Bit[2]	C/D	-	RAM	0	Block error state (section 5.2)
7	PV	DS-65	C/D				Analog data
	1 Status	Usign8	C/D	-	RAM	bad, non-specific	PV Status
	2 Value	Float	C/D	-	RAM	0	PV Value
8	OUT	DS-65	O/N				Output data from the AI
	1 Status	Usign8	O/N	-	RAM	bad, non-specific	OUT Status
	2 Value	Float	O/N	MAN	EEP	0	OUT Value
9	SIMULATE	DS-82	C/D				Pass the specified value to FIELD_VAL or PV in place of the value received from the TB.
	1 Simulate Status	Usign8	C/D	ANY	RAM	bad, non-specific	Status of the manually set value
	2 Simulate Value	Float	C/D	ANY	RAM	0	Manually set value
	3 Transducer Status	Usign8	C/D	-	RAM	bad, non-specific	Status of the value received from the TB
	4 Transducer Value	Float	C/D	-	RAM	0	Value received from the TB

\*1 Initial values for eight AIs are AI-1, AI-2, AI-3, AI-4, AI-5, AI-6, AI-7, and AI-8 respectively.

\*2 Initial values for eight AIs are 40400, 40410, 40420, 40430, 40440, 40450, 40460, and 40470, respectively.

R	Parameter	Data Type	Attribute	Write	Store	Initial Value	Description
5	Enable/Disable	Usign8	C/D	ANY	RAM	disable	Turns On/Off Simulate 1: simulate Disabled (disable output of the manually set value) 2: simulate Enabled (enable output of the manually set value)
10	XD_SCALE	DS-68	C/S				Scaling variable The scaled value is FIELD_VAL.
1	EU at 100 %	Float	C/S	OOS	EEP	100	100% value (engineering unit)
2	EU at 0 %	Float	C/S	OOS	EEP	0	0% value (engineering unit)
3	Units Index	Usign16	C/S	OOS	EEP	%	Unit (enter using a value) 1001: °C, 1243: mV, etc.
4	Decimal Point	Usign8	C/S	OOS	EEP	0	Number of digits below the decimal point to be displayed
11	OUT_SCALE	DS-68	C/S				Scaling variable The scaled value is PV.
1	EU at 100 %	Float	C/S	OOS	EEP	100	100% value (engineering unit)
2	EU at 0 %	Float	C/S	OOS	EEP	0	0% value (engineering unit)
3	Units Index	Usign16	C/S	OOS	EEP	%	Unit (enter using a value) 1001: °C, 1243: mV, etc.
4	Decimal Point	Usign8	C/S	OOS	EEP	0	Number of digits below the decimal point to be displayed
12	GRANT_DENY	DS-70	C/D				Not used
1	Grant	Bit[1]	C/D	ANY	RAM	0	Not used
2	Deny	Bit[1]	C/D	ANY	RAM	0	Not used
13	IO_OPTS	Bit[2]	C/S	OOS	EEP	0	Specify the selections for the process procedure of the output parameter (OUT). The DX/MV supports only low cut (bit 10 is 1).
14	STATUS_OPTS	Bit[2]	C/S	OOS	EEP	propagate failure	Specify the selections for the process procedure of the Status of the output parameter (OUT). The DX/MV only supports "pass the value to OUT without activating the alarm even when the Status from the TB is "Bad, Device Failure" or "Bad, sensor failure."
15	CHANNEL	Usign16	C/S	OOS	EEP	1*	Channel number for connecting the TB and AI (specify 1 through 8)
16	L_TYPE	Usign8	C/S	MAN	EEP	direct	Method in making the value from the TB into FIELD_VAL or PV. 1: Direct 2: Indirect 3: Ind Sqr Root
17	LOW_CUT	Float	C/S	ANY	EEP	0	Low cut value for the PV (value with an engineering unit, non-negative value)
18	PV_FTIME	Float	C/S	ANY	EEP	0	Time constant of the first order delay filter for the PV (the unit is seconds)

\* Initial values for eight AIs are 1, 2, 3, 4, 5, 6, 7, and 8 respectively.

## Appendix 2 Parameters

R	Parameter	Data Type	Attribute	Write	Store	Initial Value	Description
19	FIELD_VAL	DS-65	C/D				Analog value
	1 Status	Usign8	C/D	-	RAM	bad, non-specific	FIELD_VAL Status
	2 Value	Float	C/D	-	RAM	0	FIELD_VAL Value
20	UPDATE_EVT	DS-73	C/D				Update event state
	1 Unacknowledged	Usign8	C/D	ANY	RAM	ack	See the explanation of the RB parameter.
	2 Update State	Usign8	C/D	-	RAM	report	See the explanation of the RB parameter.
	3 Time Stamp	Time	C/D	-	RAM	0	See the explanation of the RB parameter.
	4 Static Revision	Usign16	C/D	-	RAM	0	See the explanation of the RB parameter.
	5 Relative Index	Usign16	C/D	-	RAM	0	See the explanation of the RB parameter.
21	BLOCK_ALM	DS-72					Block alarm status
	1 Unacknowledged	Usign8	C/D	ANY	RAM	ack	See the explanation of the RB parameter.
	2 Alarm State	Usign8	C/D	-	RAM	report	See the explanation of the RB parameter.
	3 Time Stamp	Time	C/D	-	RAM	0	See the explanation of the RB parameter.
	4 Subcode	Usign16	C/D	-	RAM	0	See the explanation of the RB parameter.
	5 Value	Usign8	C/D	-	RAM	0	See the explanation of the RB parameter.
22	ALARM_SUM	DS-74	C/D				Displays the alarm summary of the AI
	1 Current	Bit[2]	C/D	-	RAM	0	See the explanation of the RB parameter.
	2 Unacknowledged	Bit[2]	C/D	-	RAM	0	See the explanation of the RB parameter.
	3 Unreported	Bit[2]	C/D	-	RAM	0	See the explanation of the RB parameter.
	4 Disabled	Bit[2]	C/S	ANY	EEP	0xffff	See the explanation of the RB parameter.
23	ACK_OPTION	Bit[2]	C/S	ANY	EEP	0	Sets auto acknowledge of the alarm (specify the alarm to auto acknowledge using bits. Section 3.9)
24	ALARM_HYS	Float	C/S	ANY	EEP	0.5	Alarm hysteresis Specify in the range 0 to 50% of the alarm value (for HI, HI_HI, LO, and LO_LO alarms)
25	HI_HI_PRI	Usign8	C/S	ANY	EEP	0	Priority of the HI_HI alarm Value: 0, 1, 3 through 15
26	HI_HI_LIM	Float	C/S	ANY	EEP	+INF	HI_HI alarm value for OUT (value with the same engineering unit as OUT)
27	HI_PRI	Usign8	C/S	ANY	EEP	0	Priority of the HI alarm Value: 0, 1, 3 through 15
28	HI_LIM	Float	C/S	ANY	EEP	+INF	HI alarm value for OUT (value with the same engineering unit as OUT)
29	LO_PRI	Usign8	C/S	ANY	EEP	0	Priority of the LO alarm Value: 0, 1, 3 through 15
30	LO_LIM	Float	C/S	ANY	EEP	-INF	LO alarm value for OUT (value with the same engineering unit as OUT)
31	LO_LO_PRI	Usign8	C/S	ANY	EEP	0	Priority of the LO_LO alarm Value: 0, 1, 3 through 15
32	LO_LO_LIM	Float	C/S	ANY	EEP	-INF	LO_LO alarm value for OUT (value with the same engineering unit as OUT)
33	HI_HI_ALM	DS-71	C/D				HI_HI Alarm state
	1 Unacknowledged	Usign8	C/D	ANY	RAM	ack	Response to the alarm transmission 1: Acknowledged (acknowledged, specifiable) 2: Unacknowledged (no acknowledge)

R	Parameter	Data Type	Attribute	Write	Store	Initial Value	Description
2	Alarm State	Usign8	C/D	-	RAM	report	Alarm transmission 1: Clear-Reported (cleared, transmitted) 2: Clear-Not reported (cleared, not transmitted) 3: Active-Reported (active, transmitted) 4: Active-Not reported (active, not transmitted)
3	Time Stamp	Time	C/D	-	RAM	0	Time when the alarm occurred
4	Subcode	Usign16	C/D	-	RAM	0	Not used
5	Value	Float	C/D	-	RAM	0	OUT value when the alarm occurred
34	HI_ALM	DS-71	C/D				HI Alarm state
1	Unacknowledged	Usign8	C/D	ANY	RAM	ack	See the description of the HI_HI alarm section.
2	Alarm State	Usign8	C/D	-	RAM	report	See the description of the HI_HI alarm section.
3	Time Stamp	Time	C/D	-	RAM	0	See the description of the HI_HI alarm section.
4	Subcode	Usign16	C/D	-	RAM	0	See the description of the HI_HI alarm section.
5	Value	Float	C/D	-	RAM	0	See the description of the HI_HI alarm section.
35	LO_ALM	DS-71	C/D				LO alarm state
1	Unacknowledged	Usign8	C/D	ANY	RAM	ack	See the description of the HI_HI alarm section.
2	Alarm State	Usign8	C/D	-	RAM	report	See the description of the HI_HI alarm section.
3	Time Stamp	Time	C/D	-	RAM	0	See the description of the HI_HI alarm section.
4	Subcode	Usign16	C/D	-	RAM	0	See the description of the HI_HI alarm section.
5	Value	Float	C/D	-	RAM	0	See the description of the HI_HI alarm section.
36	LO_LO_ALM	DS-71	C/D				LO_LO alarm state
1	Unacknowledged	Usign8	C/D	ANY	RAM	ack	See the description of the HI_HI alarm section.
2	Alarm State	Usign8	C/D	-	RAM	report	See the description of the HI_HI alarm section.
3	Time Stamp	Time	C/D	-	RAM	0	See the description of the HI_HI alarm section.
4	Subcode	Usign16	C/D	-	RAM	0	See the description of the HI_HI alarm section.
5	Value	Float	C/D	-	RAM	0	See the description of the HI_HI alarm section.

## Appendix 2 Parameters

### MAI Function Block (First index number: 9000)

R	Parameter	Data Type	Attribute	Write	Store	Initial Value	Description
0	BLOCK	DS-64	C/S				Structure information of the block
	1 Block Tag	Visible[32]	C/S	OOS	EEP	MAI-1	Block tag (up to 32 characters). Must be unique within the segment.
	2 DD Member ID	Usign32	C/S	-	-	0x0	DD search key
	3 DD Item ID	Usign32	C/S	-	-	0x800209b0	DD search key
	4 DD Revision	Usign16	C/S	-	-	1	DD revision
	5 Profile	Usign16	C/S	-	-	0x0130	Block type MAI is "0x0130."
	6 Profile Revision	Usign16	C/S	-	-	0x0001	Profile revision
	7 Execution Time	Usign32	C/S	-	-	960	Execution time (the unit is 1/32 ms, read only)
	8 Period of Execution	Usign32	C/S	ANY	EEP	32000	Execution period (the unit is 1/32 ms, read only)
	9 Number of Parameters	Usign16	C/S	-	-	18	Number of parameters making up the block
	10 Next FB to Execute	Usign16	C/S	ANY	EEP	0	The FB to be executed next.
	11 Starting Index of Views	Usign16	C/S	-	-	40900	Start index of VIEW_1
	12 Number of VIEW_3	Usign8	C/S	-	-	1	Number of VIEW_3s
	13 Number of VIEW_4	Usign8	C/S	-	-	1	Number of VIEW_4s
1	ST_REV	Usign16	C/S	-	EEP	0	Static parameter revision The value increases every time a value is written to the static parameter.
2	TAG_DESC	Octet[32]	C/S	ANY	EEP	(all space)	User memo area
3	STRATEGY	Usign16	C/S	ANY	EEP	1	User memo area
4	ALERT_KEY	Usign8	C/S	ANY	EEP	1	See the explanation of the RB parameter.
5	MODE_BLK	DS-69	C/M				Mode setting and indication
	1 Target	Bit[1]	C/N	ANY	EEP	oos	Transition destination mode setting
	2 Actual	Bit[1]	C/D	-	RAM	oos	Current mode
	3 Permitted	Bit[1]	C/S	ANY	EEP	auto man oos	Permitted modes for transition
	4 Normal	Bit[1]	C/S	ANY	EEP	auto	Transition destination mode when resuming to normal operation.
6	BLOCK_ERR	Bit[2]	C/D	-	RAM	0	Block error state (section 5.2)
7	CHANNEL	Usign16	C/S	OOS	EEP	9	Channel number used to connect the TB and MAI
8	OUT_1	DS-65	O/N				Data to be output
	1 Status	Usign8	O/N	MAN	EEP	bad, non-specific	OUT_1 Status
	2 Value	Float	O/N	MAN	EEP	0	OUT_1 Value
9	OUT_2	DS-65	O/N				Data to be output
	1 Status	Usign8	O/N	MAN	EEP	bad, non-specific	OUT_2 Status
	2 Value	Float	O/N	MAN	EEP	0	OUT_2 Value
10	OUT_3	DS-65	O/N				Data to be output
	1 Status	Usign8	O/N	MAN	EEP	bad, non-specific	OUT_3 Status
	2 Value	Float	O/N	MAN	EEP	0	OUT_3 Value
11	OUT_4	DS-65	O/N				Data to be output
	1 Status	Usign8	O/N	MAN	EEP	bad, non-specific	OUT_4 Status
	2 Value	Float	O/N	MAN	EEP	0	OUT_4 Value

R	Parameter	Data Type	Attribute	Write	Store	Initial Value	Description
12	OUT_5	DS-65	O/N				Data to be output
	1 Status	Usign8	O/N	MAN	EEP	bad, non-specific	OUT_5 Status
	2 Value	Float	O/N	MAN	EEP	0	OUT_5 Value
13	OUT_6	DS-65	O/N				Data to be output
	1 Status	Usign8	O/N	MAN	EEP	bad, non-specific	OUT_6 Status
	2 Value	Float	O/N	MAN	EEP	0	OUT_6 Value
14	OUT_7	DS-65	O/N				Data to be output
	1 Status	Usign8	O/N	MAN	EEP	bad, non-specific	OUT_7 Status
	2 Value	Float	O/N	MAN	EEP	0	OUT_7 Value
15	OUT_8	DS-65	O/N				Data to be output
	1 Status	Usign8	O/N	MAN	EEP	bad, non-specific	OUT_8 Status
	2 Value	Float	O/N	MAN	EEP	0	OUT_8 Value
16	UPDATE_EVT	DS-73	C/D				Update event state
	1 Unacknowledged	Usign8	C/D	ANY	RAM	ack	See the explanation of the RB parameter.
	2 Update State	Usign8	C/D	-	RAM	report	See the explanation of the RB parameter.
	3 Time Stamp	Time	C/D	-	RAM	0	See the explanation of the RB parameter.
	4 Static Revision	Usign16	C/D	-	RAM	0	See the explanation of the RB parameter.
	5 Relative Index	Usign16	C/D	-	RAM	0	See the explanation of the RB parameter.
17	BLOCK_ALM	DS-72	C/D				Block alarm status
	1 Unacknowledged	Usign8	C/D	ANY	RAM	ack	See the explanation of the RB parameter.
	2 Alarm State	Usign8	C/D	-	RAM	report	See the explanation of the RB parameter.
	3 Time Stamp	Time	C/D	-	RAM	0	See the explanation of the RB parameter.
	4 Subcode	Usign16	C/D	-	RAM	0	See the explanation of the RB parameter.
	5 Value	Usign8	C/D	-	RAM	0	See the explanation of the RB parameter.



## Appendix 2 Parameters

### MAO Function Block (First index number: 10000)

R	Parameter	Data Type	Attribute	Write	Store	Initial Value	Description
0	BLOCK	DS-64	C/S				Structure information of the block
1	Block Tag	Visible[32]	C/S	OOS	EEP	MAO-1	Block tag (up to 32 characters). Must be unique within the segment.
2	DD Member ID	Usign32	C/S	-	-	0x0	DD search key
3	DD Item ID	Usign32	C/S	-	-	0x800209d0	DD search key
4	DD Revision	Usign16	C/S	-	-	1	DD revision
5	Profile	Usign16	C/S	-	-	0x0131	Block type, MAO is "0x0131."
6	Profile Revision	Usign16	C/S	-	-	0x0001	Profile revision
7	Execution Time	Usign32	C/S	-	-	960	Execution time (the unit is 1/32 ms, read only)
8	Period of Execution	Usign32	C/S	ANY	EEP	32000	Execution period (the unit is 1/32 ms, read only)
9	Number of Parameters	Usign16	C/S	-	-	29	Number of parameters making up the block
10	Next FB to Execute	Usign16	C/S	ANY	EEP	0	The FB to be executed next.
11	Starting Index of Views	Usign16	C/S	-	-	41000	Start index of VIEW_1
12	Number of VIEW_3	Usign8	C/S	-	-	1	Number of VIEW_3s
13	Number of VIEW_4	Usign8	C/S	-	-	1	Number of VIEW_4s
1	ST_REV	Usign16	C/S	-	EEP	0	Static parameter revision. The value increases every time a value is written to the static parameter.
2	TAG_DESC	Octet[32]	C/S	ANY	EEP	(all space)	User memo area
3	STRATEGY	Usign16	C/S	ANY	EEP	1	User memo area
4	ALERT_KEY	Usign8	C/S	ANY	EEP	1	See the explanation of the RB parameter.
5	MODE_BLK	DS-69	C/M				Mode setting and indication
1	Target	Bit[1]	C/N	ANY	EEP	oos	Transition destination mode setting
2	Actual	Bit[1]	C/D	-	RAM	oos	Current mode
3	Permitted	Bit[1]	C/S	ANY	EEP	auto man oos	Permitted modes for transition
4	Normal	Bit[1]	C/S	ANY	EEP	auto	Transition destination mode when resuming to normal operation.
6	BLOCK_ERR	Bit[2]	C/D	-	RAM	0	Block error status (section 5.2)
7	CHANNEL	Usign16	C/S	OOS	EEP	10	Channel number used to connect the TB and MAO
8	IN_1	DS-65	I/N				Retrieved data
1	Status	Usign8	I/N	-	RAM	bad, not connect	IN_1 Status
2	Value	Float	I/N	ANY	RAM	0	IN_1 Value
9	IN_2	DS-65	I/N				Retrieved data
1	Status	Usign8	I/N	-	RAM	bad, not connect	IN_2 Status
2	Value	Float	I/N	ANY	RAM	0	IN_2 Value
10	IN_3	DS-65	I/N				Retrieved data
1	Status	Usign8	I/N	-	RAM	bad, not connect	IN_3 Status
2	Value	Float	I/N	ANY	RAM	0	IN_3 Value
11	IN_4	DS-65	I/N				Retrieved data
1	Status	Usign8	I/N	-	RAM	bad, not connect	IN_4 Status
2	Value	Float	I/N	ANY	RAM	0	IN_4 Value
12	IN_5	DS-65	I/N				Retrieved data
1	Status	Usign8	I/N	-	RAM	bad, not connect	IN_5 Status
2	Value	Float	I/N	ANY	RAM	0	IN_5 Value

R	Parameter	Data Type	Attribute	Write	Store	Initial Value	Description
13	IN_6	DS-65	I/N				Retrieved data
	1 Status	Usign8	I/N	-	RAM	bad, not connect	IN_6 Status
	2 Value	Float	I/N	ANY	RAM	0	IN_6 Value
14	IN_7	DS-65	I/N				Retrieved data
	1 Status	Usign8	I/N	-	RAM	bad, not connect	IN_7 Status
	2 Value	Float	I/N	ANY	RAM	0	IN_7 Value
15	IN_8	DS-65	I/N				Retrieved data
	1 Status	Usign8	I/N	-	RAM	bad, not connect	IN_8 Status
	2 Value	Float	I/N	ANY	RAM	0	IN_8 Value
16	MO_OPTS	Bit[2]	C/S	ANY	EEP	0	Set the process procedure of IN_1 through IN_8 Values. Bit 0: Set whether to store (1: yes/0: no) the FSTATE_VAL1 value to IN_1 Value when IN_1 lapse into fault state. Bit 1: IN_2, FSTATE_VAL2 Bit 2: IN_3, FSTATE_VAL3 Bit 3: IN_4, FSTATE_VAL4 Bit 4: IN_5, FSTATE_VAL5 Bit 5: IN_6, FSTATE_VAL6 Bit 6: IN_7, FSTATE_VAL7 Bit 7: IN_8, FSTATE_VAL8 Bits 8-15: See section 3.7
17	FSTATE_TIME	Float	C/S	ANY	EEP	0	Time from the point when IN_1 through IN_8 become abnormal to the point when transition is made to Fault State.
18	FSTATE_VAL1	Float	C/S	ANY	EEP	0	Value to store in IN_1 Value when IN_1 enters the Fault State condition
19	FSTATE_VAL2	Float	C/S	ANY	EEP	0	Value to store in IN_2 Value when IN_2 enters the Fault State condition
20	FSTATE_VAL3	Float	C/S	ANY	EEP	0	Value to store in IN_3 Value when IN_3 enters the Fault State condition
21	FSTATE_VAL4	Float	C/S	ANY	EEP	0	Value to store in IN_4 Value when IN_4 enters the Fault State condition
22	FSTATE_VAL5	Float	C/S	ANY	EEP	0	Value to store in IN_5 Value when IN_5 enters the Fault State condition
23	FSTATE_VAL6	Float	C/S	ANY	EEP	0	Value to store in IN_6 Value when IN_6 enters the Fault State condition
24	FSTATE_VAL7	Float	C/S	ANY	EEP	0	Value to store in IN_7 Value when IN_7 enters the Fault State condition
25	FSTATE_VAL8	Float	C/S	ANY	EEP	0	Value to store in IN_8 Value when IN_8 enters the Fault State condition
26	FSTATE_STATUS	Usign8	C/D	-	RAM	0	Indicates whether IN_1 through IN_8 is in the Fault State condition. Bit 0: 1 when IN_1 is fault state Bits 1-7: Corresponds to the IN_2 through IN_8 conditions
27	UPDATE_EVT	DS-73	C/D				Update event state
	1 Unacknowledged	Usign8	C/D	ANY	RAM	ack	See the explanation of the RB parameter.
	2 Update State	Usign8	C/D	-	RAM	report	See the explanation of the RB parameter.
	3 Time Stamp	Time	C/D	-	RAM	0	See the explanation of the RB parameter.
	4 Static Revision	Usign16	C/D	-	RAM	0	See the explanation of the RB parameter.
	5 Relative Index	Usign16	C/D	-	RAM	0	See the explanation of the RB parameter.
28	BLOCK_ALM	DS-72	C/D				Block alarm status
	1 Unacknowledged	Usign8	C/D	ANY	RAM	ack	See the explanation of the RB parameter.
	2 Alarm State	Usign8	C/D	-	RAM	report	See the explanation of the RB parameter.
	3 Time Stamp	Time	C/D	-	RAM	0	See the explanation of the RB parameter.

## Appendix 2 Parameters

R	Parameter	Data Type	Attribute	Write	Store	Initial Value	Description
4	Subcode	Usign16	C/D	-	RAM	0	See the explanation of the RB parameter.
5	Value	Usign8	C/D	-	RAM	0	See the explanation of the RB parameter.

### Link Object (Index number 30000 to 30025)

Parameter	Data Type	Attribute	Write	Store	Initial Value	Description
FB Link	DS-81	-				Link Object
1 Local Index	Usign16	-	ANY	EEP	0	See section 3.11.
2 VCR Number	Usign16	-	ANY	EEP	0	See section 3.11.
3 Remote Index	Usign16	-	ANY	EEP	0	See section 3.11.
4 Service Operation	Usign8	-	ANY	EEP	0	See section 3.11.
5 Stale Count Limit	Usign8	-	ANY	EEP	0	See section 3.11.

### Alert Object (Index number 31000 to 31002)

Parameter	Data Type	Attribute	Write	Store	Initial Value	Description
Alert	DS-75	-				Alert Object
1 Block Index	Usign16	-	-	-	-	First index No. of the block alarm occurred
2 Alert Key	Usign8	-	-	-	-	A copy of ALERT_KEY value
3 Standard Type	Usign8	-	-	-	-	Type of alarm 1: LO - Low limit 2: HI - High limit 3: LO_LO - Critical low limit 4: HI_HI - Critical high limit 8: BLOCK - Block alarm 9: UPDATE - Static data update 10: WRITE - Write protect changed
4 Mfr Type	Usign8	-	-	-	0	Not used
5 Message Type	Usign8	-	-	-	-	Cause of alert 1: Event Notification (update event) 2: Alarm Clear 3: Alarm Occur
6 Priority	Usign8	-	-	-	-	Priority of alert (1 to 15)
7 Time Stamp	Time	-	-	-	-	Time alarm or update event occurred
8 Subcode	Usign16	-	-	-	-	Subcode (see section 4.2)
9 Value	Float	-	-	-	-	Value (see section 4.2)
10 Relative Index	Usign16	-	-	-	-	Relative index number of the parameter that indicate the state of the alarm (BLOCK_ALM, HI_ALM, WRITE_ALM, UPDATE_EVT, etc.)
11 Unit Index	Usign16	-	-	-	-	A copy of Unit Index of the parameters that indicate alarm state (HI_ALM, WRITE_ALM, etc). For BLOCK_ALM and UPDATE_EVT, 0 enters.

**Trend Object (Index number 32000 to 32007)**

Parameter	Data Type	Attribute	Write	Store	Initial Value	Description
Trend Float	DS-78	-				Trend Object
1 Block Index	Usign16	-	ANY	EEP	0	See section 3.8.
2 Relative Index	Usign16	-	ANY	EEP	0	See section 3.8.
3 Sample Type	Usign8	-	ANY	EEP	0	See section 3.8.
4 Sample Interval	Usign32	-	ANY	EEP	0	See section 3.8.
5 Last Update	Time	-	-	-	-	The last sampling time
6 Status	Usign8	-	-	-	-	Status* of the sampled data
:	:	-	-	-	-	:
21 Status	Usign8	-	-	-	-	Status of the sampled data
22 Value	Float	-	-	-	-	Value* of the sampled data
:	:	-	-	-	-	:
37 Value	Float	-	-	-	-	Value of the sampled data

\* Status of the subindex No.6 and Value of the subindex No.22 are Status and Value of the the latest data.

**Veiw Object**

See section 1.2.

# Index

## A

ACK_OPTION	3-24, App-16, App-22
Actual	3-8
Adding the DX/MV to the Fieldbus	3-2
AI Function Block	1-3
AI_MAP	3-10, App-18
ALARM_HYS	3-22, App-22
ALARM_SUM	3-24, 4-4, App-15, App-19, App-22
Alert Auto Acknowledge	3-24
Alert Object	1-5
Alert Priority	3-22
Alert Retransmission Time	3-23
Alert Status Transition	4-2
ALERT_KEY	App-12, App-17, App-20, App-24, App-26
AP_CLOCK_SYNC_INTERVAL	App-6
Auto	3-8

## B

Basic Device	1-1, App-1
BLOCK	App-12, App-17, App-20, App-24, App-26
Block Errors	5-8
Block Mode	3-8
Block Tag	3-4
BLOCK_ALM	4-3, App-15, App-17, App-22, App-25, App-27
BLOCK_ERR	4-3, 5-8, App-12, App-17, App-20, App-24
BOOT_OPERAT_FUNCTIONAL_CLASS	3-30, App-9
Bus Powered Device	1-1

## C

CHANNEL	3-10, 3-15, 3-17, App-21, App-24, App-26
CHANNEL_STATES_VARIABLE	App-10
Clamp Filter	2-2
Client/Server	App-1
CLR_FSTATE	3-19, App-14
COLLECTION_DIRECTORY	App-18
Communication Input Data	3-16
Computation Channel	3-6
CONFIGURED_LINK_SETTING_RECORD	3-31, 3-32
CONFIRM_TIME	3-23, App-15
Connection	2-2
CURRENT_LINK_SETTING_RECORD	App-9
CURRENT_TIME	App-6
CYCLE_SEL	App-13
CYCLE_TYPE	App-13

## D

Data Attributes	App-11
Data Type	App-5
DD_RESOURCE	App-13
DD_REV	App-13
DEV_ID	App-6, App-19
DEV_KEY	App-19
DEV_REV	App-13
DEV_TYPE	App-13
Device Description	3-1
DEVICE_STATUS	5-12
DEVICE_STATUS_1	App-16
DEVICE_STATUS_2	App-16
DEVICE_STATUS_3	App-16

DEVICE_STATUS_4	App-16
DEVICE_STATUS_5	App-16
DEVICE_STATUS_6	App-16
DEVICE_STATUS_7	App-16
DEVICE_STATUS_8	App-16
DLME_BASIC_CHARACTERISTICS	App-8
DLME_BASIC_INFO	App-9
DLME_LINK_MASTER_CAPABILITIES_VARIABLE	App-9
DLME_LINK_MASTER_INFO_RECORD	App-9
DLME_SCHEDULE_DESCRIPTOR.1	App-10
DLME_SCHEDULE_DESCRIPTOR.2	App-10
DOMAIN.1	App-10
DOMAIN.2	App-10

## E

EEPROM_STATE	App-19
EXEC_FB_CNT	App-19
Execution Time	1-11

## F

Fault State	3-18
FAULT_STATE	3-19, App-14
FB-VFD	1-9
FB_START_ENTRY	3-29, App-6
FEATURE_SEL	App-13
FEATURES	App-13
FG (Frame Ground)	2-2
FIELD_VAL	App-22
FIELD_VAL (AI) Status	5-5
FIELDBUS DATA screen	4-7
Filter	3-14
First Unpolled Node Id	3-31
FOUNDATION Fieldbus H1	1-1
FREE_SPACE	App-14
FREE_TIME	App-14
FSTATE_STATUS	3-19, App-27
FSTATE_TIME	3-19, App-27
FSTATE_VAL1	App-27
FSTATE_VAL1 to FSTATE_VAL8	3-19
FSTATE_VAL2	App-27
FSTATE_VAL3	App-27
FSTATE_VAL4	App-27
FSTATE_VAL5	App-27
FSTATE_VAL6	App-27
FSTATE_VAL7	App-27
FSTATE_VAL8	App-27
Function Block Virtual Field Device	1-9

## G

GRANT_DENY	App-13, App-21
------------	----------------

## H

HARD_TYPES	App-13
HI_ALM	4-2, App-23
HI_HI_ALM	4-2, App-22
HI_HI_LIM	App-22
HI_HI_PRI	App-22
HI_LIM	3-22, App-22
HI_PRI	3-22, App-22

## Index

Host ..... 4-1

## I

I/O Parameter Status ..... 5-1  
IDs ..... 1-1  
IN\_1 ..... App-26  
IN\_2 ..... App-26  
IN\_3 ..... App-26  
IN\_4 ..... App-26  
IN\_5 ..... App-26  
IN\_6 ..... App-27  
IN\_7 ..... App-27  
IN\_8 ..... App-27  
Index No. .... 1-10  
Initial Value ..... App-6, App-12  
IO\_OPTS ..... 3-13, App-21

## L

L\_TYPE ..... 3-11, App-21  
LIM\_NOTIFY ..... 3-23, App-14  
Limit ..... 5-3  
Link Master Device ..... 1-1, App-2  
Link Master Function ..... 1-12, 5-14  
Link Object ..... 1-4, 3-26  
LINK\_SCHEDULE\_ACTIVATION\_VARIABLE ..... App-10  
LINK\_SCHEDULE\_LIST\_CHARACTERISTICS\_RECORD  
..... App-10  
Live List ..... 1-12  
LIVE\_LIST\_STATUS\_ARRAY\_VARIABLE ..... App-9  
LO (Local Override) ..... 3-8  
LO\_ALM ..... 4-2, App-23  
LO\_LIM ..... App-22  
LO\_LO\_ALM ..... 4-2, App-23  
LO\_LO\_LIM ..... App-22  
LO\_LO\_PRI ..... App-22  
LO\_PRI ..... App-22  
LOCAL\_TIME\_DIFF ..... App-6  
Low Cut ..... 3-13  
LOW\_CUT ..... 3-13, App-21

## M

MACRO\_CYCLE\_DURATION ..... 3-29, App-6  
MAI Function Block ..... 1-3  
MAI\_MAP ..... 3-15, App-18  
Man ..... 3-8  
Management Information Base Virtual Field Device ..... 1-9  
MANUFAC\_ID ..... App-13  
MAO Function Block ..... 1-3  
MAO\_MAP ..... 3-16, App-18  
Max Response Delay ..... 3-32  
MAX\_NOTIFY ..... App-14  
MAX\_TOKEN\_HOLD\_TIME\_ARRAY ..... App-9  
MEMORY\_SIZE ..... App-13  
MIB-VFD ..... 1-9  
Min Inter Pdu Delay ..... 3-32  
MIN\_CYCLE\_T ..... App-13  
MO\_OPTS ..... 3-18, App-27  
MODE\_BLK .... 3-8, App-12, App-17, App-20, App-24, App-26

## N

Node Address ..... 1-1, 3-4  
Node Address Range ..... 3-31  
Normal ..... 3-9

Number of Consecutive Unpolled Node Id ..... 3-31  
NV\_CYCLE\_T ..... App-14

## O

Object Dictionary ..... App-2  
OOS ..... 3-8  
OPERATIONAL\_POWERUP ..... App-6  
OUT ..... App-20  
OUT (AI) Status ..... 5-4  
OUT\_1 ..... App-24  
OUT\_2 ..... App-24  
OUT\_3 ..... App-24  
OUT\_4 ..... App-24  
OUT\_5 ..... App-25  
OUT\_6 ..... App-25  
OUT\_7 ..... App-25  
OUT\_8 ..... App-25  
OUT\_SCALE ..... 3-12, App-21

## P

### Parameter

AI Function Block ..... App-20  
Alert Object ..... App-28  
Link Object ..... App-28  
MAI Function Block ..... App-24  
Management Information Base VFD ..... App-5  
MAO Function Block ..... App-26  
Resource Block ..... App-12  
Transducer Block ..... App-17  
Trend Object ..... App-29  
Parameters ..... 1-9  
Parameters Related to Alert ..... 3-21  
PD Tag ..... 1-1, 3-4  
PD\_TAG ..... 3-4, App-6  
Period of Execution ..... 1-11  
Permitted ..... 3-8  
PLME\_BASIC\_CHARACTERISTICS ..... App-10  
PLME\_BASIC\_INFO ..... App-10  
PRIMARY\_AP\_TIME\_PUBLISHER ..... App-6  
PRIMARY\_LINK\_MASTER\_FLAG\_VARIABLE ..... App-9  
Process Alarm ..... 3-21  
Publisher/Subscriber ..... App-1  
PV ..... App-20  
PV\_FTME ..... 3-14, App-21

## Q

Quality ..... 5-1  
Quality Sub-status ..... 5-1

## R

Relative Index No. .... 1-10  
Report distribution ..... App-2  
Resource Block ..... 1-3  
Response (Alert) ..... 4-2  
RESTART ..... App-13  
RS\_STATE ..... 5-11, App-12

## S

Scaling ..... 3-12  
Schedule ..... 1-11, 3-29, App-2  
Scheduled Communications ..... 1-12, App-3  
Scheduler ..... App-2

SET\_FSTATE ..... 3-19, App-14  
 SHED\_RCAS ..... App-14  
 SHED\_ROUT ..... App-14  
 SIM\_ENABLE\_MSG ..... 4-5, App-16  
 SimEnable ..... 2-2, 4-5  
 SIMULATE ..... App-20  
 Simulation Function ..... 4-5  
 Simulation Jumper ..... 4-5  
 Simulation Values ..... 4-6  
 Slot Time ..... 3-32  
 SM\_SUPPORT ..... App-6  
 SOFT\_DESC ..... App-16  
 SOFT\_REV ..... App-16  
 Specifications ..... 2-1  
 ST\_REV ..... App-12, App-17, App-20, App-26  
 STACK\_CAPABILITIES ..... App-7  
 STACK\_CONF ..... App-19  
 STACK\_STATISTICS\_1 ..... App-19  
 STACK\_STATISTICS\_2 ..... App-19  
 Starting the Operation ..... 4-1  
 States of the Resource Block ..... 5-10  
 Status of IN-1 through IN-8 (MAO) ..... 5-6  
 Status of OUT\_1 through OUT\_8 (MAI) ..... 5-5  
 Status Structure ..... 5-1  
 STATUS\_OPTS ..... 3-14, App-21  
 Storage Type ..... App-11  
 STRATEGY ..... App-12, App-17, App-20, App-24, App-26  
 Structure of AI Function Block ..... 3-10  
 Structure of Functions ..... 1-2  
 Structure of MAI Function Block ..... 3-15  
 Structure of MAO Function Block ..... 3-16  
 Sub Index No. .... 1-10  
 System and Network Management Function ..... 1-4

## T

T1 ..... App-6  
 T2 ..... App-6  
 T3 ..... App-6  
 TAG\_DESC ..... App-12, App-17, App-20, App-24, App-26  
 Target ..... 3-8  
 Terminal Arrangement ..... 2-2  
 TEST\_RW ..... App-12  
 This Node ..... 3-4  
 Time Synchronization ..... 1-12  
 TIME\_LAST\_RCVD ..... App-6  
 TIME\_PUBLISHER\_ADDR ..... App-6  
 Transducer Block ..... 1-3  
 TRANSDUCER\_DIRECTORY ..... App-17  
 TRANSDUCER\_TYPE ..... App-17  
 Transition to Scheduler ..... App-3  
 Trend Object ..... 1-5, 3-20

## U

UART\_STATISTICS ..... App-19  
 Unscheduled Communications ..... 1-12, App-4  
 UPDATE\_EVT .....  
 ..... 4-4, App-15, App-17, App-22, App-25, App-27

## V

Value of Input/Output Data ..... 5-6  
 VCR ..... 1-4  
 VCR\_DYNAMIC\_ENTRY ..... App-8  
 VCR\_LIST\_CHARACTERISTICS ..... App-7  
 VCR\_LIST\_CONTROL ..... App-7

VCR\_STATIC\_ENTRY ..... 3-27, App-7  
 VERSION\_OF\_SCHEDULE ..... App-6  
 View Object ..... 1-6  
 Virtual Communication Relationship ..... 1-4, 3-27, App-4  
 Virtual Field Device ..... App-4

## W

Write Mode ..... App-11  
 WRITE\_ALM ..... 4-3, App-16  
 WRITE\_LOCK ..... 3-25, App-15  
 WRITE\_PRI ..... 3-23, App-16

## X

XD\_ERROR ..... 5-8, App-17  
 XD\_SCALE ..... 3-12, App-21